

CITY OF SUFFOLK

STANDARD SPECIFICATIONS FOR EIGHT PHASE

GROUND MOUNTED TRAFFIC SIGNAL CONTROLLER

CABINETS

REVISION K – Release 3.1
(NEMA TS 2- 2003 Standard)

January 10, 2007



Revision K, - Release 3

These are cumulative changes since Revision K, - Release 1

Title Sheet

Introduction Sheet – Added note on general layout of cabinet and attached prints

Replaced prints with updated version

SECTION 1

2.2.6.1 – Dimension Modification (change the word “aluminum” to “stainless”)

2.2.7 – Deleted words “manual” and “automatic” in last sentence of paragraph.

3.6 – Change the word “duel” to “dual”

3.6.1 – Added note for Appendix D

Added Appendix C

Added Appendix D

SECTION 2

2.1.1.2 – Added additional clarification on Camera Interface Panel

2.1.2 - Added note on location of detector rack

2.13 – Change the phrase “from all phase, overlap,” to “from each detector channel in rack,”

5.1- Added note for Appendix C

6.6.4 – Added note for location of Power Supply

INTRODUCTION

The intent of this specification is to describe the physical, electrical, and operational requirements of eight phase ground mounted traffic signal controller cabinets and auxiliary equipment. This specification does not include traffic signal controller units. The controller cabinets and auxiliary equipment described herein and amended by the plans, request for quotation or purchase order where applicable, shall be furnished complete, ready for installation and shall be fully compatible with Quixote Traffic Incorporated's Model ATC Traffic Signal Controller, TS-2 units.

QUESTIONS

Questions regarding these specifications and, where applicable, accompanying plans, Request for Quotation or Purchase Order should be directed to the DPW/Traffic Engineering Division, City of Suffolk.

757-514-7603

General Layout of Cabinet

The cabinet shall conform to these specifications and shall have all panels located as shown on sheets 1-6 of the following prints titled "16 LDSW Cabinet Assy Suffolk VA" dated 11-05-07 by Quixote Traffic Corporation.

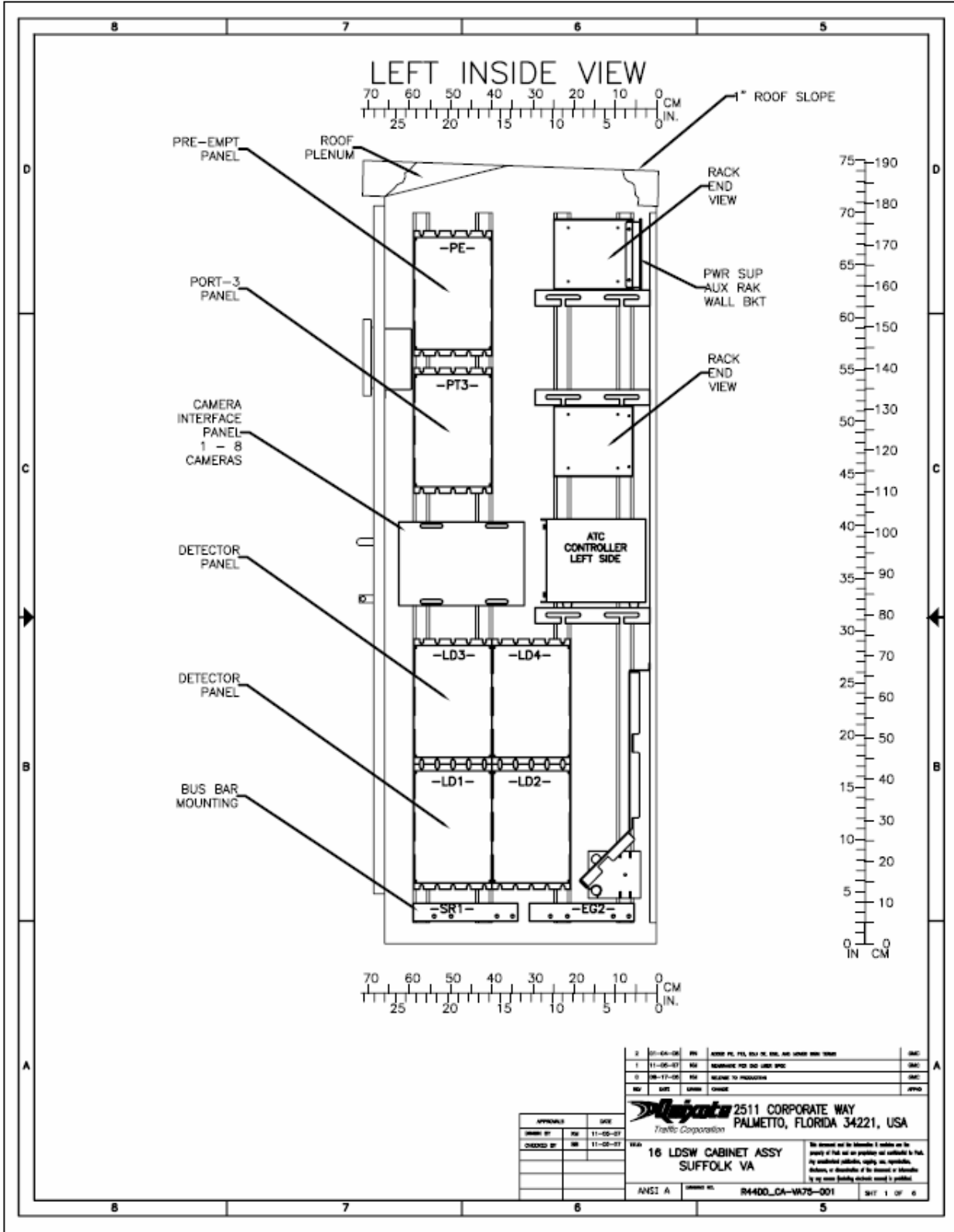

FRONT VIEW

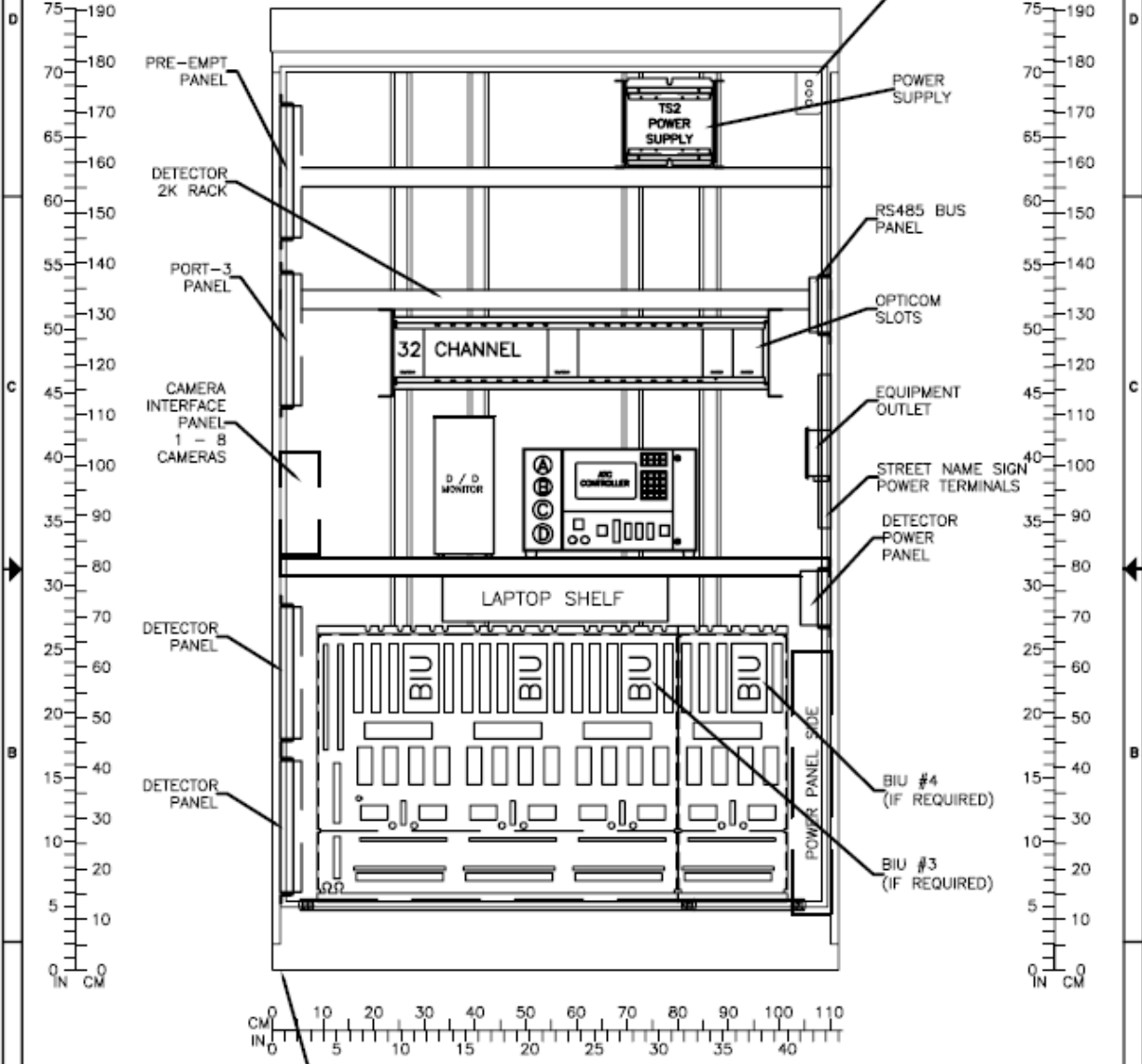
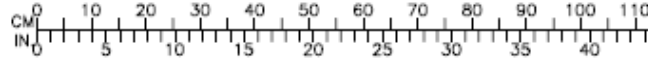

3" WIDE X 1/4" THICK ANCHOR FLANGE ALL AROUND

2	01-04-08	REV	REVISED FOR FIELD USE AND ADDITIONAL PARTS	ENC
1	11-08-07	REV	REWORKING FOR THE USER SPEC	ENC
0	09-17-05	REV	ISSUE TO PRODUCTION	ENC
REV	DATE	BY	CHANGE	APP'D

Alipata Traffic Corporation
 2511 CORPORATE WAY
 PALMETTO, FLORIDA 34221, USA

16 LDSW CABINET ASSY
 SUFFOLK VA

ANSI A DRAWING NO. R4400_CA-WA75-001 SHEET 2 OF 4

We warrant and the Manufacturer's liability on the property of that set on packages and materials is that they conform to the specifications, drawings, and instructions of the customer or Manufacturer. No other liability (including consequential damages) shall be assumed by the Manufacturer.

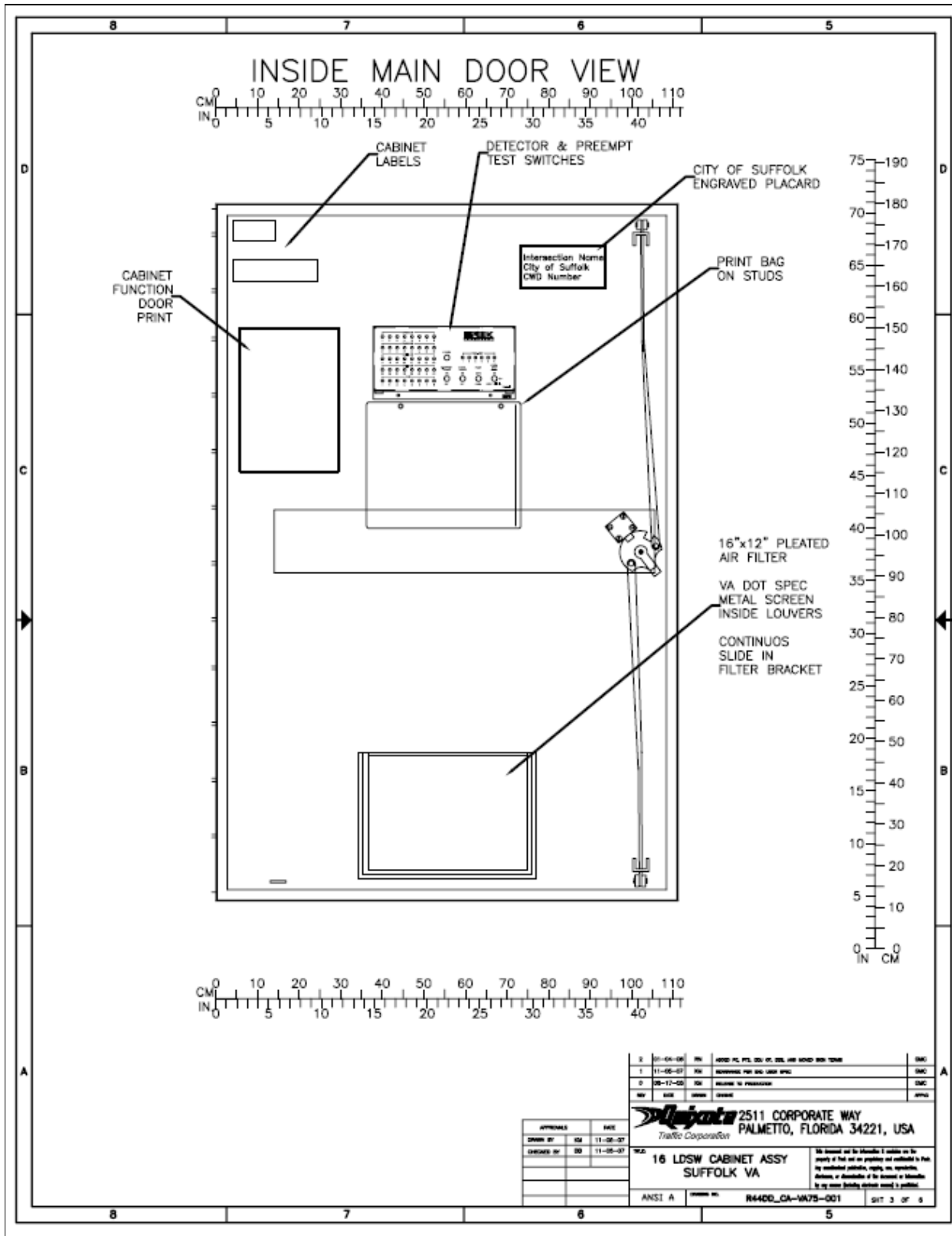

2	01-01-08	REV	ADD P.C. P.L. 200 OF 200 AND ADD 800 TONE	DMC
1	11-05-07	REV	ADJUSTMENT FOR BAG LABEL PRINT	DMC
0	08-17-05	REV	ISSUE FOR PRODUCTION	DMC
REV	DATE	BY	REASON	APPROV

Palmetto 2511 CORPORATE WAY
Traffic Corporation PALMETTO, FLORIDA 34221, USA

16 LDSW CABINET ASSY
SUFFOLK VA

ANSI A

APPROVALS	DATE
DRAWN BY: DM	11-05-07
CHECKED BY: DM	11-05-07

We warrant our products to be free from defects in material or workmanship for a period of 12 months from the date of purchase. This warranty does not cover damage caused by misuse, accident, or other causes not within our control.

RIGHT INSIDE VIEW

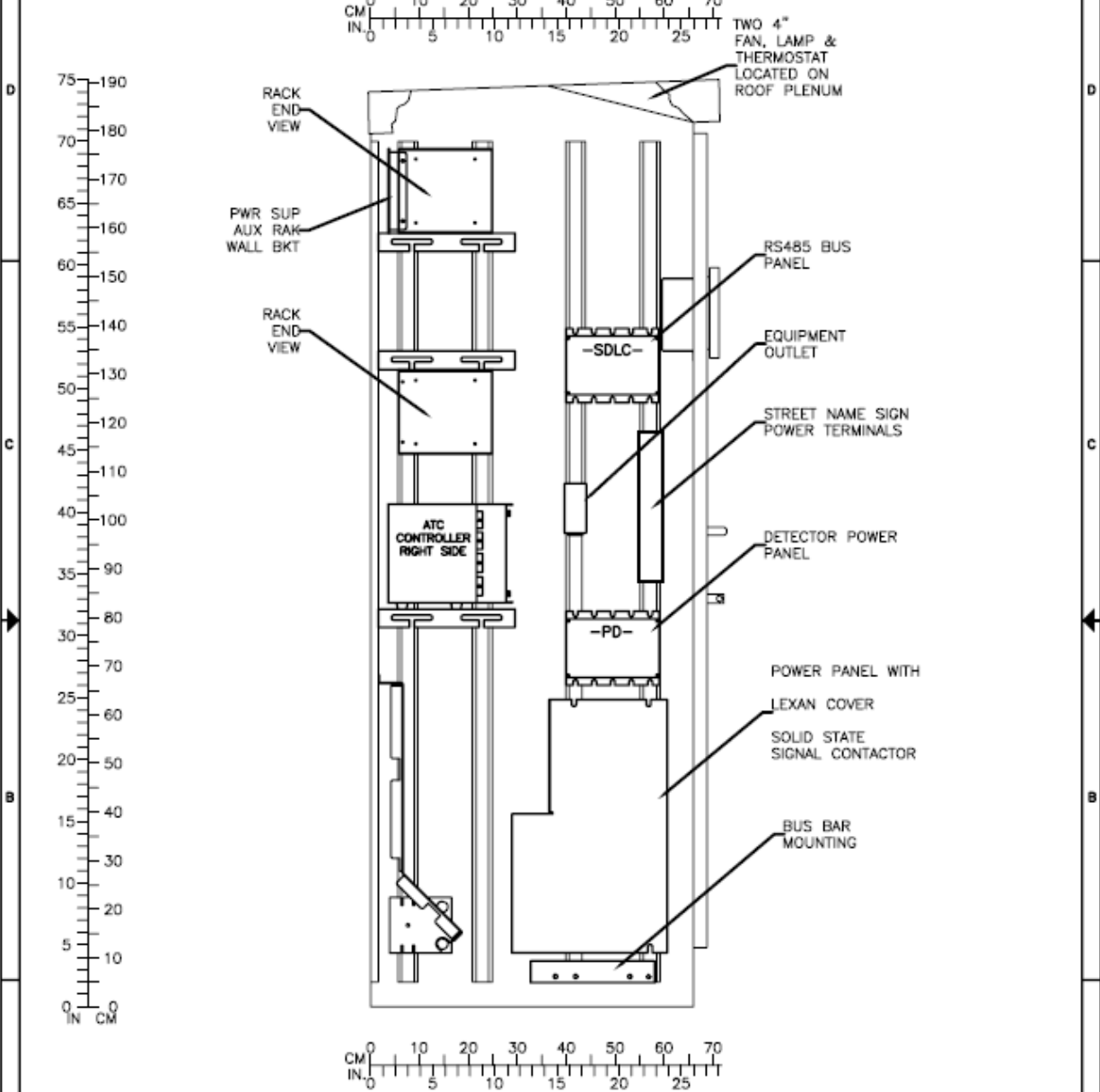

2	11-04-08	SM	ADDED PL. TEL. BOX PL. BOX AND WIRE BOX TOWER	SMC
1	11-06-07	SM	REWORKED FOR ONE USER SPACE	SMC
2	08-17-06	SM	ISSUED TO PRODUCTION	SMC
REV	DATE	BY	REASON	APPRO

Palmetto Traffic Corporation
 2511 CORPORATE WAY
 PALMETTO, FLORIDA 34221, USA

16 LDSW CABINET ASSY
 SUFFOLK VA

ANSI A DRAWING NO. **R4400_CA-V075-001** SHEET 4 OF 6

We warrant and be liable to others on the property of Palmetto and its products and materials to the extent of the manufacturer's liability, including, but not limited to, damages, or availability of the product or materials to any other liability, contract or otherwise.

APPROVALS	DATE
DRAWN BY: SM	11-06-07
CHECKED BY: SM	11-06-07

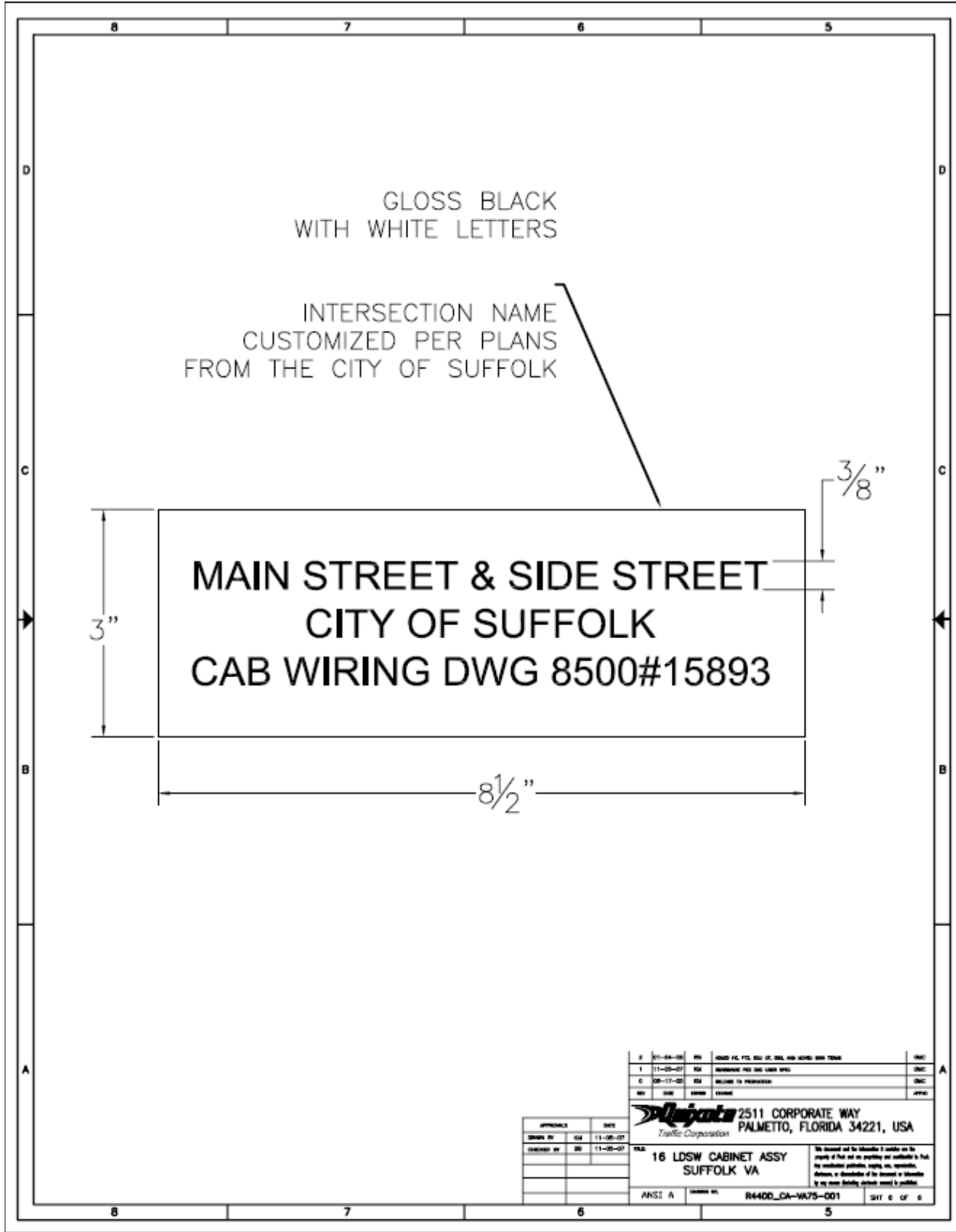

SECTION ONE

SPECIFICATION CABINET ASSEMBLY

1.0 SCOPE

This specification sets forth the minimum requirements for a control cabinet assembly. The cabinet assembly shall meet, as a minimum, all applicable sections of the NEMA Standard Publication No. TS-2 2003. All cabinets shall meet the requirements of a NEMA 3 R rating, and shall be U.L. listed as an entire unit. Where differences occur, this specification shall govern.

2.0 CABINET DESIGN AND CONSTRUCTION

2.1 GENERAL

2.1.1 The cabinet and door(s) shall be constructed from type 5052-H32 aluminum with a minimum thickness of 0.125 inches. The top, door, and each side of the cabinet shall each be a single sheet of aluminum. Welding pieces together to form any of these surfaces shall not be permitted. External welds shall be made by using the Heliarc welding method, whereas internal welds will be made by the wire welding method. All welds shall be neatly formed and free of cracks, blowholes, and other irregularities.

2.1.2 All inside and outside edges of the cabinet shall be free of burrs. All sharp edges shall be made smooth.

2.1.3 The cabinet shall be designed and manufactured with materials that will allow ridged mounting, whether intended for pole, base or pedestal mounting. The cabinet must not flex on its mounting.

2.1.4 A rain channel shall be incorporated on all four (4) sides of the main door opening to prevent liquids from entering the enclosure. Cabinet door openings shall be double flanged outward on all four (4) sides to produce the rain channel.

2.1.5 The top of the cabinet shall incorporate a 1" (inch) slope toward the rear to prevent rain accumulation.

2.1.6 The cabinet shall be supplied with a natural aluminum finish. Sufficient care shall be taken in handling to ensure that scratches are minimized. All surfaces shall be cleaned of all oil residues and shall be free from weld flash.

2.1.7 All interior seams shall be sealed with RTV sealant or equivalent material.

2.1.8 All cabinets shall be supplied with three removable shelves manufactured from 5052-H32 aluminum having a minimum thickness of 0.125 inches. Shelves shall have a minimum depth of 10.5 inches.

2.1.9 One set of vertical "C" channels shall be mounted on each interior wall of the cabinet for the purpose of mounting the cabinet components. The size seven (7) cabinets shall have an additional set of channels mounted on the left and right side walls. The mounting channels shall provide infinite horizontal and vertical adjustments of mounted equipment and shelves. The channels shall accommodate spring-mounted nuts or studs. All mounting rails shall extend to within four (4) inches of the top and

bottom of the cabinets. Rivets or pop-rivets of any kinds shall not be used in the cabinet or on the main panel. No bolts or screws shall protrude through the outside walls, top, bottom, or sides of the cabinet.

2.1.10 All cabinets shall be supplied with four (4) anchor bolts to properly secure the cabinet to its base. Bolt patterns for the size seven (7) cabinets shall be used as shown in Figure 7.8.3.2 of the NEMA Standards.

2.1.11 The cabinet shall have an open bottom that is surrounded by a heavy duty attachment flange (lip) made of double thickness material having a minimum thickness of 0.25 inches. Around the opening, the flange shall be three (3) inches wide, plus or minus one-half (2) inch. One inch slots shall be provided in all four corners for the anchor bolts or for securing the removable bottom panel of pole mounted cabinets.

2.1.12 Each cabinet shall be of sufficient size to accommodate all equipment without crowding. Each piece of equipment shall have its own space on a shelf. It shall not be necessary to move any other piece of equipment in order to service any component or unit. All auxiliary equipment shall be accessible for removal or installation without moving any other component in the cabinet. The minimum cabinet size is as follows:

→ Size 7 (Modified) Cabinets - 75" H x 44" W x 26" D

2.1.13 All cabinets shall be equipped with a three (3) position alarm and light switch bracket. This bracket shall be attached to the top right corner of the door opening.

2.1.14 The complete cabinet circuitry diagram shall be shown on a 24" x 36" drawing.

2.1.15 The diagram shall include the designated intersection location as specified on the plans or purchase order.

2.1.16 Included on the diagram shall be an intersection plan view with all poles, cabinet phases and detectors shown. The City will provide a software copy of the intersection plans in AutoCAD format.

2.1.17 The complete cabinet circuitry diagram shall also be supplied on a digital compact computer disk in AutoCAD (latest version) Windows format.

2.1.18 A listing indicating all terminal numbers with a description of its use shall be attached to the inside of the cabinet door and overlaid with a clear plastic covering. All edges of the plastic shall extend beyond the listing and be sealed with a clear weatherproofing compound.

2.1.19 A 2" X 4" (minimum size) identification plate with the intersection name, the City of Suffolk, and cabinet circuitry diagram number shall be permanently affixed to the inside of the main cabinet door in the upper right hand corner. An engraved plastic plate is preferred.

2.1.20 All size seven (7) cabinets shall have a rear door similar to the main door excluding the police panel

2.2 DOORS and HARDWARE

2.2.1 A stiffener plate shall be welded across the inside of the main door to prevent flexing. The stiffener plate shall not cover or prevent access to any door component(s).

2.2.2 The lower section of the cabinet door shall be equipped with a louvered air entrance. The air inlet shall be large enough to allow sufficient airflow per the rated fan capacity. Louvers must satisfy the NEMA rod entry test for 3R ventilated enclosures. A removable, fiberglass air filter shall be supplied with each cabinet. The filter shall be secured to the air entrance in such fashion as to maintain close contact, at all times, to the louvered air entrance. The filter retainer shall be a slide fit design with no bolts or springs utilized to secure the filter to the door opening.

2.2.3 The roof of the cabinet shall incorporate an exhaust plenum with a vent screen. Perforations in the vent screen shall not exceed 0.125 inches in diameter.

2.2.4 The main door and rear door shall be equipped with a three-point draw roller type latching mechanism. The push rods shall be turned edgewise at the outward supports and shall be 0.250 inch by 0.750 inch aluminum minimum. The push rods shall maintain a uniform thickness along their entire length. A reduction in thickness at the center latch point shall not be accepted.

2.2.4.1 Rollers shall have a minimum diameter of 0.875 inches and will be made of nylon. The center catch shall be fabricated from 0.187 aluminum minimum.

2.2.5 The handle on both doors shall utilize a stainless steel shank of 5/8 inches minimum diameter. The handle shall include a hasp for the attachment of an optional padlock. The cabinet door handle shall rotate counter-clockwise to open. The handle shall not extend beyond the perimeter of the main door at any time. The lock assembly shall be positioned so that the handle shall not cause any interference with the key when opening the cabinet door. When the door is closed and latched, the door shall automatically lock. It shall not be necessary to use a key in order to lock the door.

2.2.6 The main cabinet doors and police panel door hinges shall be a one-piece, continuous piano hinge. The hinge shall be located on the right side of the door when viewed from the front. The hinge and pin shall run the entire length of the door. All cabinet and police panel door hinge pins shall be capped at the top and bottom by weld to render the pin tamper proof.

2.2.6.1 The hinges shall be made of 0.078-inch thick stainless and shall have a 2-inch open width with a 0.250-inch diameter stainless steel hinge pin. Door hinge shall be bolted to the cabinet and door with a 1/4-20 stainless steel carriage bolts and ny-lock nuts.

2.2.7 The main door and rear shall be equipped with a mechanism to automatically hold the door open at approximately 90, 125, and 150 degrees, in windy conditions. The mechanism shall be pinned to prevent separation from the track. The door holding track shall be reinforced and tack welded along its top and bottom. Manual placement of the mechanism shall not be required by the field technician. A manual door holding mechanism shall be provided at the opposite end of the door from the above noted system for use in high wind conditions.

2.2.8 The main door and rear door shall be equipped with a Corbin tumbler lock number 15481RS or approved equivalent. The lock shall be of brass construction, and shall have a swing-away cover. Two Virginia No. 2 keys shall be supplied and attached to each cabinet door upon shipment

2.3 POLICE SWITCH COMPARTMENT

2.3.1 A switch compartment shall be provided on the main door.

2.3.2 The opening for the switch compartment door shall be double flanged on all four sides and shall incorporate a rain channel on all four sides.

2.3.3 The police door-in-door shall be provided with a treasury type lock Corbin No. R357SGS series, or approved equivalent. The lock shall be of brass construction, and shall have a swing away cover. All cabinets shall have a police panel door that utilizes a slam shut type latching mechanism. Two police keys shall be supplied and attached to each cabinet door upon shipment.

2.3.4 The door hinge for the switch compartment shall be 0.063-inch stainless steel with a 0.120-inch diameter stainless steel hinge pin.

3.0 TYPE 1 TERMINALS AND FACILITIES MAIN PANEL DESIGN

3.1 The main panel shall be constructed from 5052-H32 brushed aluminum of 0.090 inches minimum thickness and formed so as to minimize any flexing when plug-in components are installed.

3.2 All main panels shall be hinged at the bottom to allow easy access to all wiring on the rear of the panel. The cabinet back panel conductors shall be arranged to allow the top of the panel to be tilted out through the main cabinet door. Removal or disconnecting of any conductors or equipment mounted on the side walls of the cabinet shall not be necessary.

3.3 The main panels shall be fully wired in the following configuration:

→ Type 1 Configuration 4 - Sixteen load switch sockets, (eight vehicle sockets, four pedestrian sockets and four overlap sockets) eight flash transfer relay sockets, one flasher socket and two main panel BIU rack positions.

3.4 Reference designators for all load switch and flash transfer relay sockets shall be silk-screen labeled on the front and rear of the main panel.

→ Up to eight load switch sockets may be positioned horizontally or stacked in two rows on the main panel. If more than eight load switch sockets are required, they shall be mounted in two horizontal rows. All load switch sockets and flash transfer sockets shall be mounted on the main panel only.

3.5 A support located at approximately 2/3 the length of the load switch shall support all load switches. This support must be rigidly mounted to the main panel and be removable for maintenance without the use of hand tools.

3.6 In Type 1 Main Panels, rack style mounting shall be provided to accommodate the required BIU's per the configuration listed in section 3.3 above. A **dual** - row, 64 - pin female din 41612 Type B connector shall be provided for each BIU rack position. Card guides shall be provided for both edges of the BIU. Terminal and facilities BIU

mounting shall be an integral part of the main panel. Detector rack BIU mounting shall be an integral part of the detector rack.

3.6.1 In Type 1 Main Panels all BIU rack connectors shall have pre-wired address pins corresponding to the requirements of the TS 2 Specification. The address pins shall control the BIU mode of operation. BIU's shall be capable of being interchanged with no additional programming. **The BIU pin outs shall be as shown in Appendix D**

3.7 All sixteen position main panels shall have all field wires terminated within one or two rows of horizontally mounted terminal blocks. If two rows are used, the upper row shall be wired for the pedestrian and overlap field terminations. The lower row shall be reserved for phase one through eight vehicle field terminations.

3.7.1 A loading resistor having a nominal value of 2,000 ohms - 11 watt, shall be installed between the ground buss and each green and yellow signal output field connection terminal for vehicle phases one through eight, each overlap movement, and each pedestrian walk movement.

3.7.2 A loading resistor having a nominal value of 2,000 ohms - 11 watt, shall be installed between the ground buss and red signal output field connection terminal for vehicle phases 1, 3, 5, 7, each overlap movement, and each pedestrian don't walk movement.

3.8 All field output circuits shall be terminated on a non-fused terminal block with a minimum rating of 20 amps.

3.9 Permanent alphanumerical labels shall identify all field input / output (I/O) terminals. All labels shall use standard nomenclature per the NEMA TS 2 Specification.

3.9.1 Type 1 Main Panels shall have as a minimum, terminals provided for the input / output signals listed in table 5.3.1 - 2 for terminal facilities configurations 3 and 4 of NEMA TS 2 - 2003 Standard.

3.10 All flash color selection shall be accomplished at a terminal block located just above the field terminals with the use of a screwdriver only. It shall also be possible to select through terminal connections which of the two flasher circuits is connected to each phase. All cabinets shall be wired so that flasher circuit output #1 shall be wired for phases 2, 3, 6, and 7, overlap B and overlap D. Flasher output circuit #2 shall be wired for phases 1, 4, 5, and 8, overlap A and overlap C. Unless otherwise specified on plans, purchase order or request for bid, all cabinets shall be pre-wired to flash phases 2 and 6 yellow and all other phases and overlaps red.

3.11 Field terminal blocks shall be wired to use three positions per vehicle, pedestrian and overlap phase. All bolts and screws used for electrical connections shall be stainless steel. All equipment grounds shall run directly and independently to the Earth ground bus bar. All neutral conductors shall be carried throughout the cabinet without a break, splice, or fuse unless otherwise noted. A separate insulated Neutral Bus Bar with a minimum of twenty positions sized to allow three #12 wires per terminal shall be mounted to the lower portion of the cabinet wall on each side of the cabinet. A separate Earth Ground Bus Bar with a minimum of ten positions sized to allow three #12 wires per terminal shall be mounted to the lower portion of the cabinet wall on each side of the cabinet. The mounting of each bus bar shall be ridged with minimal flexing at all points on the bar.

3.11.1 Signal output terminals shall be screw type, Compression type termination shall not be acceptable.

3.12 The power panel shall contain a flasher socket capable of operating a 15-amp, 2-pole, NEMA solid state flasher. A bracket that extends at least half its length shall support the flasher.

3.13 As a minimum, a RC network shall be wired in parallel with each group of three flash-transfer relay coils. A RC network shall be installed on all other relay coils.

3.14 All logic-level, NEMA Controller Unit and Malfunction Management Unit input and output terminations on the main panel shall be permanently labeled. Cabinet prints shall identify the function of each terminal position. All screws and terminals shall be made of stainless steel.

3.15 Type 1 Main Panel terminal blocks for DC signal interfacing shall have a number 6-32 x 7/32-inch screw as a minimum. All screws and terminals shall be made of stainless steel. Functions to be terminated shall be as specified in the listing of input / output Terminals in the NEMA TS 2 - 2003 Standard document (Section 5).

3.16 All main panel wiring shall conform to the following wire size and color:

Green or Walk load switch output	brown wire	16 AWG
Yellow load switch output	yellow wire	16 AWG
Red/Don't Walk load switch output	red wire	16 AWG
MMU (other than AC power)	optional color	22 AWG
Controller Unit Input / Output	blue wire	22 AWG
AC Line (power panel to main panel)	black wire	***
AC Line (main panel)	black wire	***
AC Neutral (power panel to main panel)	white wire	***
AC Neutral (main panel)	white wire	***
Earth ground (power panel)	green wire	***
Logic ground	gray wire	22 AWG

*** Gauge varies with power panel / main panel set.
 Unless otherwise noted, wire size shall comply with NEMA Standard
 TS 2 - 2003 Table 5.2.5 - 1.

3.17 All wiring, 20 AWG and smaller, shall conform to MIL-W-16878/1, type B, 600V, 19-strand tinned copper. The wire shall have PVC insulation and be rated to 105 degrees Celsius. All 18 AWG and larger wire shall be UL 1028, 105 degrees Celsius, 600 V, PVC insulation.

3.18 All Controller Unit and Malfunction Management Unit cables shall be of sufficient length to allow the units to be placed on either shelf in the operating mode. Connecting cables shall be sleeved in a braided nylon mesh. The use of exposed tie-wraps or interwoven cables are unacceptable.

3.19 All cabinet configurations shall be provided with enough RS-485 Port 1 communication cables to allow full capabilities of that cabinet. Each communication cable connector shall be a 15-pin metal shell D sub-miniature type. The cable shall be a shielded cable suitable for RS-485 communications.

3.20 All main panels shall be pre-wired for a Type-16 Malfunction Management Unit.

3.21 All wiring shall be neat in appearance. All cabinet wiring shall be continuous from its point of origin to its termination point. Butt type connections/splices are not acceptable. Printed circuit boards, except for BIU rack shall not be used on main panels.

3.22 All connecting cables and wire runs shall be secured by mechanical clamps. Stick-on type clamps are not acceptable.

3.23 The grounding system in the cabinet shall be divided into three separate circuits (AC Neutral, Earth Ground and Logic Ground). These ground circuits shall be connected together at a single point as outlined in the NEMA TS 2 Standard.

3.24 All pedestrian push-button inputs from the field to the controller shall be opto-isolated and operate at 12 VAC.

3.25 All wire (size 16 AWG or smaller) at solder joints shall be hooked or looped around the eyelet or terminal prior to soldering to ensure circuit integrity. Lap joint soldering is not acceptable. All connections from the main panel to other cabinet components shall be on the front of the main panel and shall be made with insulated spade connectors.

3.26 All exposed or protruding 120 VAC terminals or screws shall be covered or shielded to prevent shock hazard to personnel.

3.27 All conductors used in cabinet wiring shall be identified on the cabinet wiring drawing by color and gauge. All unused wires shall be terminated at a terminal strip and identified on the cabinet wiring diagram. The tying back of unused wires is not acceptable. All wiring harnesses shall be encased in a continuous mesh sheath. The use of cable ties to arrange wiring harnesses is not acceptable. All conductors and wiring harnesses shall be routed and arranged to allow easy access to all equipment and terminals.

3.28 The main panel shall incorporate a relay to remove +24 VCD from the common side of the load switches when the intersection is placed into flash. The main panel shall incorporate a relay or interlock that will initiate stop time to the controller on ring 1 and ring 2 whenever the intersection goes into a "conflict flash" condition. The relays mentioned above shall be Potter & Brumfield, Model KRAP-N11AG-120V or approved

equal.

3.29 A metal oxide varistor shall be placed at the output for each signal circuit.

4.0 POWER PANEL DESIGN AND CONSTRUCTION

4.1 The power panel shall consist of a separate panel securely fastened to the lower right side wall of the cabinet. The power panel shall be wired to provide the necessary power to the cabinet, controller, Malfunction Management Unit, cabinet power supply, and auxiliary equipment. It shall be manufactured from 0.090 inch, 5052-H32 aluminum with removable plastic front cover. Means shall be provided to allow access to the main and auxiliary breakers without removing the front cover. All components of the power panel shall be accessible for ease of replacement without removing any other components or equipment. Adequate space between components shall be provided for the tightening of all terminals.

4.2 The power panel shall be identical for all cabinets except for breaker sizing. The power panel shall house the following components:

- All circuit breakers shall be single pole Square-D or approved equivalent and supplied in a Q.O.U. mounting. The main breaker shall be labeled "MAIN." A 50 AMP circuit breaker shall be installed in size 7 cabinets. This breaker shall supply power to the controller, MMU, signals, cabinet power supply. Breakers shall be thermal magnetic type, UL listed for HACR service, with a minimum of 10,000 amp interrupting capacity. All breakers shall be installed in a vertical orientation.
- One (1) single pole fifteen amp (15-amp) breaker labeled "Auxiliary" shall supply power to the fans, lights, and GFCI outlet. The power feed for this breaker shall not be fed from the load side of the main breaker, but will be fed from the main feed side.
- One (1) single pole ten amp (10-amp) breaker shall be labeled "ELECTRONIC EQUIPMENT". The power feed for this breaker shall be from the "line out equipment" side of the power line surge protector (EDCO Surrestor SHA-1250). No substitute shall be allowed. Both the AC+ and AC- (neutral) from the EDCO Surrestor shall power the Controller Unit, Malfunction Management Unit, Power Supply, and no other equipment.
- One (1) single pole fifteen amp (15-amp) breaker labeled "Street name signs" shall supply power for internally illuminated street name signs. A four pole barrier type terminal for terminating four (4) No. 10 AWG field wiring conductors shall be provided for field wiring connected to 120 VAC from this breaker. Two terminals for the common conductors, isolated from the cabinet ground and a ground terminal, grounded to the cabinet shall be provided.
- A 60-amp, 125 VAC radio interference line filter.

- A normally open, 60-amp, solid state contactor with L.E.D. indicator shall be supplied.
- One (1) Insulated AC Neutral bus bar with a minimum of twelve (12) positions capable of accepting three #12 wires per position.
- One (1) Earth ground bus bar (chassis ground) with a minimum of seven (7) positions large enough to accept three #12 wires per position.
- A NEMA type 5-15R GFCI convenience outlet wired as specified.
- A six (6) position (minimum) terminal block shall be provided for the termination of the AC+ Feed to the cabinet, the AC-Neutral Feed to the cabinet and the Earth Ground or (Chassis Ground) to the cabinet. The terminal block shall be a “Dead Front, Finger Safe” style. It shall be completely covered with insulating material rated to 75 degrees Celsius. Access holes shall be provided for the screwdriver slots. The terminal block shall be rated for 90A, 600V. It shall have a compression type terminals capable of accepting as a minimum #14 AWG to a maximum #4 AWG copper wire in each terminal. Means shall be provided for installing or tighten the cabinet service feeds without removing the power panel protective cover.

4.3 A clear Plexiglas shield shall be installed over the incoming power panel equipment using standoffs and thumbscrews. The shield shall have an opening to provide for the manual operation of the circuit breakers.

SECTION TWO

SPECIFICATION AUXILIARY CABINET EQUIPMENT

1.0 AUXILIARY CABINET EQUIPMENT

1.1 The cabinet shall be provided with two thermostatically controlled (adjustable between 80 - 150 degrees Fahrenheit) ventilation fans in the top of the cabinet plenum. Each fan shall be a ball bearing type fan and shall be capable of drawing a minimum of 100 cubic feet of air per minute. The fans shall have a minimum design life of one hundred thousand (100,000) hours. Each fan shall have its own thermostat, fan and thermostat shall be rated for one hundred and twenty-five percent (125%) of capacity. Each fan and thermostat assemble shall be fused. All fuse holders shall be of the encased type.

1.2 A fluorescent lighting fixture shall be mounted on the inside top of the cabinet near the front edge. The fixture shall be rated to accommodate a F15T8 lamp operated from a normal power factor UL or ETL listed ballast. The fluorescent lighting fixture shall be rapid start type and cold weather rated. The lamp shall be wired to a door-activated switch mounted near the top of the door. If the main door is closed the lamp will be off.

1.3 A rigid slide-out document tray shall be mounted below the bottom shelf. The tray shall be of sufficient size and strength to hold a complete set of cabinet wiring drawings, intersection diagrams, equipment and programming manuals for all equipment and modules applicable to each cabinet. The tray shall operate by sliding out, then opening a hinged cover to remove documents. After removing the documents and closing the cover, the tray shall serve as a suitable resting place for documents or a laptop computer. As a reference, use Hennessey Products, Inc. Part No. 541.

1.4 Five (5) sets of complete and accurate cabinet wiring drawings shall be supplied with each cabinet.

1.5 One (1) set of manuals for the Controller Unit, Malfunction Management Unit, Power Supply, Detector Rack, Vehicle Detector Amplifier modules shall be supplied with each cabinet.

1.6 Ten complete sets of schematics, logic drawings, and assembly drawings for each type of electronic unit supplied (i.e., Controller Unit, MMU, Power Supply, Load Switches, and Flashers). This documentation shall be provided prior to the delivery of any equipment and shall be a one-time shipment.

1.7 Two complete copies of component, hardware, and manufacturer indices of every item, unit, assemble and component within a cabinet, shall be included as part of these specifications. A complete listing of replacement parts and sub-assemblies shall be included.

2.0 VEHICLE DETECTION RACKS

2.1 Vehicle detector amplifier rack(s) shall be provided in each cabinet.

2.1.1 Shall support two (2) Detector Racks with 16 channels of detection each, and one BIU contained within each rack.

2.1.1.1 Detector rack must include the addition of one Opticom adder back planes. Each back plane must support one Opticom Model #754 Phase selector. See Appendix B for wiring requirements. The addition of Opticom to the detector rack shall not reduce the detection channel capacity of the rack.

2.1.1.2 Shall be configured to support both rack mounted Loop Detection and Control Technologies's VIP3D.2 video detection modules including the ViewCom/E module as specified in Appendix A of these specifications. The selection of Loop versus Video detection shall be via insertion of the appropriate card in the rack and connection of the loop field wires or video input wires to the detection panel. Panel shall also include an 8 camera interface panel wired to the detector rack. **(Camera Interface Module w/ Arris Technologies, P/N IMG2-03I-NBP)**

2.1.2 Detector Rack shall be installed to hang from the bottom of the middle shelf.

2.2 Each cabinet shall contain detector interface panels for the purpose of connecting field loops and vehicle detector amplifiers. These detector panels shall be hard wired. No printed circuit type will be allowed.

2.3 One 8-position interface panel shall be provided for each 8-channel detector rack per cabinet. The interface panel(s) shall be attached to the lower left side wall of the cabinet.

2.4 Each interface panel shall allow for the connection of a minimum of eight independent field loops. A ground bus terminal shall be provided between each loop pair terminal to provide a termination for the loop lead-in ground wire. Detector Terminals shall be screw type, Compression type termination shall not be acceptable.

2.5 All Interface panels shall be provided with lightning protective devices for all channels. All interface panels shall be provided with EDCO SRA-6 or approved equal lightning protective devices for all available inputs.

2.6 A cable consisting of 20 AWG twisted pair wires shall be provided to enable connection to and from the panel to a detector rack. (Loop wires only).

2.7 All termination points shall be identified by a unique number and silk-screened on the panel.

2.8 Each detector rack shall be wired to support four (4) channel vehicle detectors. All detectors shall be interchangeable from detector rack to detector rack and from slot to slot without modification.

2.9 Each detector rack shall be powered by a shelf mounted power supply that meets the requirements of Section 5.3.5 of the NEMA TS 2 Standard.

2.10 Detector rack BIU mounting shall be an integral part of the detector rack. A dual-row, 64-pin female DIN 41612 Type B connector shall be provided for each BIU rack position. Card guides shall be provided for both edges of the BIU.

2.11 All BIU connections shall be wired to a BIU address dip switch. The address switch shall control the BIU mode of operation. BIU's shall be capable of being interchanged with no additional programming.

2.12 All wiring to the detector rack must be through connectors mounted on the detector rack, hardwiring of detector racks to cabinet wiring is not permitted.

2.13 A separate connector shall be provided to accept calls from push button test switches in the technician switch panel, one per channel. The test switches shall send calls **from each detector channel in rack**, and pedestrian phases. The technician switch panel shall be located on the cabinet auxiliary switch panel on the door. These switches shall be momentary type push button switches.

2.14 A matrix panel for assignment of detector channel to controller phase call shall not be required. This function must be available through keyboard programming.

3.0 CABINET AUXILIARY SWITCH PANEL AND POLICE PANEL

3.1 An auxiliary switch panel shall be mounted on the inside of the main door. The auxiliary switch panel shall provide as a minimum the following:

- AUTO/FLASH SWITCH. When in the FLASH position, power shall be maintained to the controller and the intersection shall be placed in flash. (MMU Local Flash). The controller shall not be stop timed when in flash. When the switch is moved from FLASH position to the AUTO position, an external start signal shall be applied to the controller. This external start signal will force the controller to initiate the start up sequence when exiting flash.
- STOP TIME ON/AUTO/OFF SWITCH. When in the ON position the controller shall be stop timed in the current interval regardless of the state of the MMU. When in the Auto position, if the MMU places the cabinet into FLASH, the controller shall be stop timed in the current interval. In the OFF position, the Stop Time input(s) will be removed from the controller regardless of the state of the MMU (Flash or normal stop/go operation).
- CONTROL EQUIPMENT POWER ON/OFF SWITCH. This switch shall control the Controller Unit, Malfunction Management Unit and Power Supply AC power. When in the ON position, the AC power shall be

applied.

SIGNAL ON / OFF. This switch shall cause the field indications to go dark, but allow the controller to continue to operate normally.

- One (1) spare switch position hole shall be provided and plugged for future use.

3.2 The police door switch panel shall contain the following:

- AUTO/FLASH SWITCH. When in the FLASH position (MMU Local Flash). The controller shall not be stop timed when in flash. When the power shall be maintained to the controller and stop time shall be applied. The intersection shall be placed in flash. When the switch is moved from FLASH position to the AUTO position, an external start signal shall be applied to the controller. This will force the controller to initiate the start up sequence when exiting flash.
- AUTO/MANUAL SWITCH. Cabinet wiring shall include provisions for an AUTO/MANUAL toggle switch and a manual control jack to accept a 1/4" monaural phone plug jack. A six (6") hand cord with a 1/4" monaural phone plug shall be provided. The switch shall be in the top position in the AUTO mode.

3.3 All toggle type switches shall be heavy duty and rated 15 amps, at a minimum. Single or double-pole switches may be provided, as required.

3.4 Any exposed terminals or switch solder points shall be covered with a non-flexible shield to prevent accidental contact.

3.5 All switch functions shall be permanently and clearly labeled.

3.6 All wire routed to the police panel and auxiliary panel shall be adequately protected against damage from repetitive opening and closing of the main door. No modular connectors will be allowed in the cabinet except for the detector panel interface. All other cabinet wiring shall be "hard wired" point to point.

4.0 INTENTIONALLY LEFT BALNK

5.0 PREEMPT INTERFACE PANEL

5.1 All cabinets shall have a Preempt panel mounted on an inside cabinet wall with the following Inputs/Outputs

INPUT		OUTPUT
Preempt No. 1		Preempt No. 1 Status
Preempt No. 2		Preempt No. 2 Status

Dimming Enable		Preempt No. 3 Status
Automatic Flash		Preempt No. 4 Status
		Preempt No. 5 Status
		Preempt No. 6 Status

See Appendix C for additional details.

5.2 Cabinet Wiring shall be provided for emergency vehicle and railroad preemption. Provisions shall also be made for test switches for emergency vehicle preemption and railroad preemption testing. These test switches can be located on the technician panel on the door.

6.0 AUXILIARY DEVICES

6.1 LOAD SWITCHES

6.1.1 Load switches shall be solid state and shall conform to the requirements of Section 6.2 of the NEMA TS 2 Standard or as specified.

6.1.2 Signal load switches shall have a minimum load current rating of 10 amperes at 120 VAC for incandescent lamp load.

6.1.3 The front of the load switch shall embody a minimum of six LED indicators. Three indicators to show the input to the load switch and three indicators to show the output of the load switch.

6.1.4 Load switches shall be dedicated per phase. The use of load switches for other partial phases is not acceptable.

6.1.5 The full complement of load switches shall be supplied with each cabinet to allow for maximum phase utilization for which the cabinet is designed.

6.2 FLASHER

6.2.1 The flasher shall be solid state design and shall conform to the requirements of section 6.3 of the NEMA TS 2 Standard.

6.2.2 The flasher shall be rated at 15 amperes, double pole with a nominal flash rate of 60 FPM.

6.3 FLASH TRANSFER RELAYS

6.3.1 All flash transfer relays shall meet the requirements of Section 6.4 of the NEMA TS 2 Standard or as specified. Contacts shall be capable of making, breaking, with a contact current rating of twenty (20) amperes.

6.3.2 The coil of the flash transfer relay must be de-energized for flash operation.

6.3.3 The full complement of flash transfer relays shall be supplied with each cabinet to allow for maximum phase utilization for which the cabinet is designed.

6.4 MALFUNCTION MANAGEMENT UNITS

6.4.1 Each cabinet assembly shall be supplied with one Malfunction Management Unit (MMU) as defined by the requirements of Section 4 of the NEMA TS 2-2003 Standard and the requirements of Section Four, Specification, Malfunction Management Unit of these specifications.

6.4.2 Malfunction Management Units shall be a Type 16.

6.4.3 Malfunction Management Units shall be wired to monitor the outputs of each load switch on a separate channel.

6.5 BUS INTERFACE UNITS

6.5.1 All Bus Interface Units (BIU's) shall meet the requirements of Section 8 of the NEMA TS 2-2003 Standard.

6.5.2 The full complement of Bus Interface Units shall be supplied with each cabinet to allow for maximum phase and function utilization for which the cabinet is designed.

6.5.3 Each Bus Interface Unit shall include power on, and transmit indicators. All indicators shall be LED's.

6.6 CABINET POWER SUPPLY

6.6.1 The cabinet power supply shall meet the requirements of Section 5.3.5 of the NEMA TS 2 Standard.

6.6.2 The cabinet power supply shall provide LED indicators for the line frequency, 12 VDC, 12 VAC, and 24 VDC outputs.

6.6.3 The cabinet power supply shall provide (on the front panel) jack plugs for access to the + 24 VDC for test purposes.

6.6.4 One (1) power supply shall be supplied with each cabinet assembly. **The Power Supply shall be bolted to the top shelf.**

6.7 VEHICLE DETECTION SYSTEM

6.7.1 Sixteen (16), Two (2) channel detectors detector amplifier that are compatible with conventional loops shall be supplied with every cabinet.

6.7.2 The following equipment shall be incorporated into the cabinet and/or included as a part of the required pluggable items for this cabinet:

- Four (4) VIP3.2 Detection Cards
- VIEWCom /E, remote monitoring and image storage module
- Video Monitor w/6' Coax Cable
- EDCO Suppressor Mounted on Panel

- Fuse Block Mounted on Panel
- Y Cable
- Zoom Lens Controller
- Programming Keypad
- ViewCom Communications module w/out Modem

Additional specifications for the Video items are contained in Appendix A.

6.8 Opticom Emergency Vehicle Detection System

6.8.1 One (1) 3M Brand Model 754 Emergency Vehicle Detection Cards shall be included with each cabinet.

6.9 Ground Fault Convenience Receptacle

APPENDIX A VIDEO DETECTION SYSTEM REQUIREMENTS

A.1 Description

The intent of the following specification is to describe the minimum requirements for providing a complete Video Detection System. Initially, the system shall be capable of providing presence vehicle detection at selected intersections. The video system shall be expandable without removing or replacing existing units.

Overview:

The purpose of the **Video Image Processor** is to detect the presence of vehicles over optical detection zones, which are placed on a standard video image (CCIR or EIA). Using standard image sensor optics & in the absence of occlusion, the system shall be able to detect vehicle presence with 98% accuracy under normal conditions (days & nights), and 96% accuracy under adverse conditions (fog, rain, snow).

All items & materials furnished shall be new, unused, current production models installed and operational in a user environment & shall be items currently in distribution. The detection algorithms shall have a proven record of field use at other installations for at least three (3) years of service; i.e., not including prototype field trials prior to installation. Video cameras shall be available commercially; no sole source cameras will be allowed.

VIDEO VEHICLE DETECTION SYSTEM

General

These technical specifications describe the minimum physical & functional properties of a video detection system. The system shall be capable of monitoring all licensed vehicles on the roadway, providing video detection for areas outlined in the construction drawings.

A.2 Materials

The entire video vehicle detection system shall consist of the following:

- 4 ea. - Detection Module VIP3D.2
- ViewCom/E – Remote Monitoring & Image Storage Module
- Video Camera(s) with IR Filter, Lens, Enclosure & Sunshield
- Luminaire Arm or Signal Mast Arm Sensor Bracket(s)
- Surge Suppressor
- Programming Devices and/or Software

- Coaxial/Power Cable
- All Other Necessary Equipment for Operation
- Training for Installation, Operation & Maintenance

The following equipment package has been pre-approved by this specification & is included in all applications:

- Traficon VIP3D.2 Video Image Processor
- Traficon ViewCom/E Remote Monitoring & Image Storage Module
- Aigis Outdoor Camera Housing – HS9384
- Aigis Camera Housing Sunshield – HS9384SS
- Rainbow Camera Model BL58D
- Rainbow Motorized Zoom Lens 6.5mm to 65mm Model – L10X65DC4P
- Rainbow B/W 9” Video Monitor Model – RMB92
- Pelco Extended Mast Arm Camera Mount – AB-0172-L-L
- Edco Suppressor – CX06-M
- Coaxial + 5 Conductor Wire – RG59U + STR PE/PVC 600V KG-9915P

1.0 Video Detection System

- 1.0 The **Video Image Processor (VIP)** shall be modular by design & housed in either a self-contained stand-alone unit or fit directly into NEMA TSI & TS2 type racks, as well as Type 170/2070 input files. The VIP shall be inter-changeable between a shelf or rack mount installation without replacing or modifying existing VIP units.
- 1.1 The system shall control from 1-6 VIP boards allowing for 1-12 image sensors.
- 1.2 The system shall be designed to operate reliably in the adverse environment of roadside cabinets & shall meet or exceed all NEMA TSI or TS2, as well as Type 170/2070, environmental specifications.
- 1.3 Ambient operating temperature shall be from -34° to 74° C at 0-95% relative humidity non-condensing.
- 1.4 The system shall be powered by 12-40 VDC & draw less than 2 amperes.
- 1.5 The system shall utilize cabinet 24 VDC for rack mount installations or external 24 VDC for stand-alone shelf installations.
- 1.6 Surge rating shall be set forth in the NEMA TS1 & TS2 specifications.
- 1.7 Serial communications shall be through an RS232 serial port. This port can be used for communications into a modem or laptop to upload/download detector configurations, count data & software upgrades. RS485 on the rear edge connector shall facilitate communications to other VIP boards.
- 1.8 Each VIP board shall have 4 opto-isolated open collector outputs. Twenty additional outputs shall be available via the expansion port. The VIP/3D shall have 20 presence detection zones & 4 data detection zones per camera. Data zones shall collect & store vehicle counts, volume, speed, gap time, headway, occupancy & classification. Data shall be time-stamped (6713 intervals) & stored onboard (non-volatile memory) in intervals from 1-60 minutes.
- 1.9 Data alarms are generated for queue, inverse direction, speed drop, no video & errors.
- 1.10 Must be able to provide single or double loop emulation.
- 1.11 Presence hold time must have parameters that range from 10-600 seconds.

- 1.12 Each VIP board shall allow for 20 digital inputs via the I/O Expansion port.
- 1.13 Each VIP board shall have error detection. Outputs will be turned “ON” if the video signal is bad or the VIP board is not functioning properly. A user defined quality level will automatically put selected outputs to recall in cases of severe degraded visibility (i.e., fog, blizzard, etc.). Normal detection resumes when visibility improves above the user defined quality level.
- 1.14 Operator selectable recall shall be available via the VIP front panel. Holding the recall switch on for 5 seconds shall activate this function.
- 1.15 A video select button on the VIP front panel will switch between camera images of the VIP3D.2.
- 1.16 The VIP3D.2 board shall have 2 video inputs (RS-170 NTSC or CCIR composite video) & 1 video out.
- 1.17 The VIP board shall have a reset button on the front panel to reset video detectors to “learn” the roadway image. During “re-learn,” selectable recall can be enabled or disabled for immediate operation. Learning time of video detectors shall be less than 6 minutes.
- 1.18 External surge suppression, independent of the VIP board, shall separate the VIP from the image sensor.
- 1.19 The VIP board shall have separate light emitting diodes (LED’s) that indicate:

Power	Red LED to verify power supply
I/O Comm	Red LED to indicate communications to expansion boards
Video 1 & 2	Red LED to verify the presence of video input 75 Ohm
TX & RX	Red LED to indicate communications to other VIP modules via the RS485
OUT1-OUT4	Green LED if the corresponding detection group is active

The VIP board shall also have 2 separate buttons for:

Video Select-Recall

Recall	Manually places call on detectors
Reset	Manually reset detectors to “learn” new background
Video Out	The VIP board shall also have a video out female RCA style connector
Service	B9 female service port & DB9 I/O Expansion port

- 1.20 The VIP Expansion board shall also have separate LED’s that indicate:

Power	Red LED to verify power supply
Comm	Red LED to indicate communications to VIP board
I/O1-I/O4	Green LED if the corresponding detection group is active

The VIP Expansion board shall have 8 dip switches that define inputs & outputs used (range: 1-12 or 13-24).

Event Log Database

The VIP module shall have an onboard database capable of time stamping & storing 500 events. The Event Log Database can be viewed or downloaded to a selected spreadsheet. Erasure of the Event Log Database shall not alter programmed configurations. As a

minimum, the VIP shall log & time stamp the following events:

- Firmware upgrade
- Loss of video signal
- Resumption of video signal
- Configuration change
- Bad video quality
- Loss of power to VIP module
- Resumption of power to VIP module
- Speed alarm
- Inverse direction
- Recall activated

Video System Communication Module

- 1.21 The communication board shall be modular by design & housed in either a self-contained stand-alone unit or fit directly into NEMA TS1 & TS2 type racks, as well as Type 170/2070 input files.
- 1.22 The communication board shall control from 1-6 VIP boards allowing for 1-12 image sensors.
- 1.23 The system shall be designed to operate reliably in the adverse environment of roadside cabinets & shall meet or exceed all NEMA TS1 & TS2, as well as Type 170/2070 environmental specifications.
- 1.24 Ambient operating temperature shall be from -34° to +74° C at 0-95% relative humidity non-condensing.
- 1.25 The system shall be powered by 12-40 VDC & draw less than 2 amperes.
- 1.26 Serial & Ethernet (TCP/IP) communications shall be through respectively an RS232 serial port (F DB9 connector) & Ethernet port (RJ-45 connection). These ports can be used for communications to a laptop or modem to upload/download detector configurations, traffic data, technical events, send software upgrades & do remote setup of detectors. RS485 on the rear edge connector shall facilitate communications to VIP boards.

1.26.1 Surge ratings shall be set forth in the NEMA TS1 & TS2 specifications.

- 2.0 The communication board shall have separate light emitting diodes (LED's) that indicate:

Power	Red LED to verify power supply
LAN	Red LED to indicate data activity over Ethernet communication
Video Out	Video out female RCA style connector
Reset	Manual reset to re-initialize communications
Service	DB9 female service port for setup of communication board & also used for serial/dial-up communication

2.0 Functional Capabilities

- 2.1 Real Time Detection
- 2.2 Each VIP board shall be capable of processing the video signal of 1 or 2 cameras. The video signal shall be analyzed in real time (30 times per second for NTSC video format & 25

frames per second for pal video format).

- 2.3 The system shall be expandable up to 12 cameras that may be connected to different VIP units & programmed independently.
- 2.4 The system shall be capable of displaying detectors on the video image with associated outputs. Outputs/inputs status will be indicated on the screen. Parameters will also include the ability to view raw video without any verbiage and/or detectors for surveillance purposes.
- 2.5 Each VIP board will detect within the view of the connected camera the presence of vehicles in user defined zones. Detectors available shall be presence, count, delay, extension or pulse mode for either arrival or departure of vehicles. Delay & extension shall be defined between 0.1-99.9 seconds & pulse mode between 0-200ms in 33ms increments if NTSC is used. Each VIP board shall also detect & collect within the view of the connected camera traffic data of passing vehicles in user-defined zones.

Collected traffic data by direction shall include:

- Volume (absolute numbers) per length class & per lane
 - Average speed (km/h or mph) per length class & per lane
 - Average gap time (1/10 sec) per length class & per lane
 - Average headway (m or feet) per lane
 - Occupancy (%) per lane
 - Concentration (vehicles/km or mile) per lane
 - Average length (m or feet) per lane
 - Confidence level (0-10) per lane
- 2.6 The VIP board shall be programmed without the use of a supervisor computer. A standard CCTV monitor & keypad plugged into the VIP serial port will facilitate detector programming.
 - 2.7 The VIP board shall store up to 4 detector configurations. It shall be possible to switch between detector configurations manually, automatically by time of day or remote input.
 - 2.8 Via the serial port, detector configurations can be uploaded to a laptop & stored on disk.
 - 2.9 Detectors may be linked to 24 outputs & 20 inputs using Boolean Logic features: AND, OR, NOT. It will be possible to generate conditional outputs based upon inputs from a controller.
 - 2.10 It shall be possible to make a detector directional sensitive. Options will include an omnidirectional detector or a detector that only senses movement: from right to left; left to right; up to down; or down to up as you look at the monitor.
 - 2.11 All detectors & parameters can be changed without interrupting detection,
 - 2.12 For example: when 1 detector is modified, all existing detectors continue to operate, including the 1 that is being modified. When the new position is confirmed, the new detector will enter a learning phase. Once the new detector is in function, it will take over the job of the old one. In this way, the detector is always fully operational with no interruption on any detector, even during modification. Learning phases for new detectors shall not exceed 6 minutes.
 - 2.13 Four (4) data detection zones per camera on a 2-camera VIP board may be used for collection of vehicle count, speed, classification, occupancy, density, headway & gap time.

Eight (8) data detection zones may be used on a single camera VIP board. These detectors

will detect & store traffic data at user-defined intervals of 1, 2, 3, 5, 6, 10, 15, 30 & 60 minutes. It shall be possible for each VIP board to store up to 6713 intervals of data in non-volatile memory.

- 2.14 Associated software may be used with a PC to download data & export to a spreadsheet. Software will also be used to upload & download detector configurations, traffic data, technical events, send software version upgrades & do remote setup of detectors.
- 2.15 The VIP board shall have an internal clock with a daylight savings time system, which can be enabled or disabled.
- 2.16 The VIP board shall provide overlaid tool tips for each individual menu & sub-menu item.
- 2.17 The VIP board shall have an optional password implementation. Different user-levels shall be available, each having different rights. A minimum of 10 users can be defined for each user-level.
- 2.18 The VIP board shall be able to delay or extend a detector zone output in combination with an input from the controller.
- 2.19 The VIP board shall detect wrong-way drivers & shall provide an alarm/event via communication board and/or output.
- 2.20 The VIP board shall provide an alarm and/or output when the user selected queue detection threshold of occupancy is exceeded for more than a user selected time threshold.
- 2.21 The VIP board shall distinguish 5 classes of detected vehicles based upon user selectable vehicle length thresholds.
- 2.22 The VIP shall be able to emulate loop emulation with user selectable loop dimensions.

Video System Communication Module

- 2.23 The Video System Communication board shall control from 1-6 VIP boards, allowing for 1-12 image sensors.
- 2.24 The Video System Communication board shall provide a serial or Ethernet interface & communication to provide traffic data & allow remote configuration from the Traffic Operations Center.
- 2.25 The LAN port shall meet IEEE 802.3 with a RJ-45 connector & meet the following specification:

Data rates for Ethernet via LAN port: 10Mbit/s
TCP/IP based protocol
- 2.26 The serial communications port shall meet EIA-232-E & meet the following specifications:
 - Dial-up data rates for RS232 via Serial port: maximum 57600 bps
 - Direct data rates for RS232 via Serial port: maximum 115200 bps
 - Mode of operation: asynchronous, serial, 8-bit word, 1 stop bit, duplex or half-duplex
 - Parity: None
 - Handshake: RTS – CTS, DCD
 - Configuration: DTE
- 2.27 The communication shall support all functions of the video detection system.

- 2.28 All data transmissions shall be protected by CRC (cyclic redundancy checking) or an equivalent error detection method.
- 2.29 The communication board shall be programmed without the use of a supervisor computer. A standard CCTV monitor & keypad plugged into the communication serial port will facilitate board programming.
- 2.30 The communication shall support streaming video over Ethernet & serial communication.
- 2.31 Password protected remote setup (configuration upload/download, setup of detectors & detector parameters, setup of communication board parameters, firmware updates for Communication & VIP module) & monitoring of every connected VIP module shall be possible.
- 2.32 Dial-up shall be possible through PSTN modems.
- 2.33 The communication board shall log data & events provided by the VIP module(s) & transmit data & events to the Host computer.
- 2.34 RS485 communication to every VIP module shall be established via the Edge connector.
- 2.35 The communication board shall be able to store on board pre-post video sequences of alarm triggered upon traffic user defined events.
- 2.36 The communication board shall be able to accept PAL or NTSC video format.
- 2.37 A (via Ethernet) connection with a standard internet browser shall be possible to communicate with the communication board for remote setup, monitoring & real-time data of the VIP modules.
- 2.38 Password protection shall be provided on the communication board for remote operations.

APPENDIX B

TYPICAL OPTICOM MODULE FUNCTIONS

-D-

OPTICOM PRE RACK ASSY
P/N 8951A

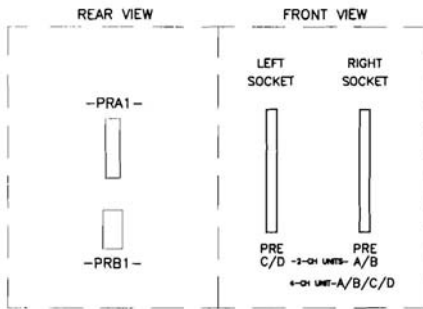

4-CHANNEL UNITS
RIGHT SOCKET

PIN(S)	FUNCTION	6909 INPUT CABLE	6901 OUTPUT CABLE
1/A	NO CONNECTION	----	----
2/B	NO CONNECTION	----	----
3/C	NO CONNECTION	----	----
4/D	A DETECTOR IN	GRAY	----
5/E	26V COMMON	ORANGE	----
6/F	A OUTPUT	----	GRAY
7/H	LOGIC GND B	----	BLUE*
8/J	B DETECTOR IN	WHT/BLK	----
9/K	26V COMMON	VIOLET	----
10/L	CHASSIS	GREEN	----
11/M	AC NEUTRAL	WHITE	----
12/N	AC LINE 115VAC	BLACK	----
13/P	C DETECTOR IN	BROWN	----
14/R	26V COMMON	RED	----
15/S	C OUTPUT	----	BROWN
16/T	LOGIC GND B	----	BLUE*
17/U	D DETECTOR IN	YELLOW	----
18/V	26V COMMON	BLUE	----
19/W	B OUTPUT	----	ORANGE
20/X	LOGIC GND B	----	BLUE*
21/Y	D OUTPUT	----	YELLOW
22/Z	LOGIC GND B	----	BLUE*

* = BLUE WIRE CONNECTS RIGHT
SOCKET TO LOGIC GROUND

PREEMPT CABLE ASSY

P/N 4159

PIN	FUNCTION	TERM
1	PRE 1 IN	PE-17
2	PRE 2 IN	PE-18
3	PRE 3 IN	PE-19
4	PRE 4 IN	PE-20
5	PRE 5 IN	PE-21
6	DETECTOR 9	PE-22
7	DETECTOR 10	PE-23
8	DETECTOR 11	PE-24
9	DETECTOR 12	PE-25
10	DETECTOR 13	PE-26
11	DETECTOR 14	PE-27
12	DETECTOR 15	PE-28
13	DETECTOR 16	PE-29
14	UCF CMND IN	PE-30
15	CAB FL IN	PE-31
16	RTC RESET	PE-32
17	PRE 6 IN	PE-33
18	DIMMING IN	PE-34
19	FREE IN	PE-35
20	T.O.D. IN	PE-36
21	PRE OUT 2	PE-37
22	USER OUT 1	PE-38
23	PRE OUT 1	PE-39
24	X-PED	PE-40
25	GROUP 2	PE-12

2-CHANNEL UNIT
LEFT SOCKET

PIN(S)	FUNCTION	6909 INPUT CABLE	6901 OUTPUT CABLE
1/A	NO CONNECTION	----	----
2/B	NO CONNECTION	----	----
3/C	NO CONNECTION	----	----
4/D	C DETECTOR IN	BROWN	----
5/E	26V COMMON	RED	----
6/F	C OUTPUT	----	BROWN
7/H	LOGIC GND A	----	VIOLET*
8/J	D DETECTOR IN	YELLOW	----
9/K	26V COMMON	BLUE	----
10/L	CHASSIS	GREEN	----
11/M	AC NEUTRAL	WHITE	----
12/N	AC LINE 115VAC	BLACK	----
13/P	NO CONNECTION	----	----
14/R	NO CONNECTION	----	----
15/S	NO CONNECTION	----	----
16/T	NO CONNECTION	----	----
17/U	NO CONNECTION	----	----
18/V	NO CONNECTION	----	----
19/W	D OUTPUT	----	YELLOW
20/X	LOGIC GND A	----	VIOLET*
21/Y	NO CONNECTION	----	----
22/Z	NO CONNECTION	----	----

* = VIOLET WIRE CONNECTS LEFT
SOCKET TO LOGIC GROUND

2-CHANNEL UNIT
RIGHT SOCKET

PIN(S)	FUNCTION	6909 INPUT CABLE	6901 OUTPUT CABLE
1/A	NO CONNECTION	----	----
2/B	NO CONNECTION	----	----
3/C	NO CONNECTION	----	----
4/D	A DETECTOR IN	GRAY	----
5/E	26V COMMON	ORANGE	----
6/F	A OUTPUT	----	GRAY
7/H	LOGIC GND B	----	BLUE*
8/J	B DETECTOR IN	WHT/BLK	----
9/K	26V COMMON	VIOLET	----
10/L	CHASSIS	GREEN	----
11/M	AC NEUTRAL	WHITE	----
12/N	AC LINE 115VAC	BLACK	----
13/P	NO CONNECTION	----	----
14/R	NO CONNECTION	----	----
15/S	NO CONNECTION	----	----
16/T	NO CONNECTION	----	----
17/U	NO CONNECTION	----	----
18/V	NO CONNECTION	----	----
19/W	B OUTPUT	----	ORANGE
20/X	LOGIC GND B	----	BLUE*
21/Y	NO CONNECTION	----	----
22/Z	NO CONNECTION	----	----

* = BLUE WIRE CONNECTS RIGHT
SOCKET TO LOGIC GROUND

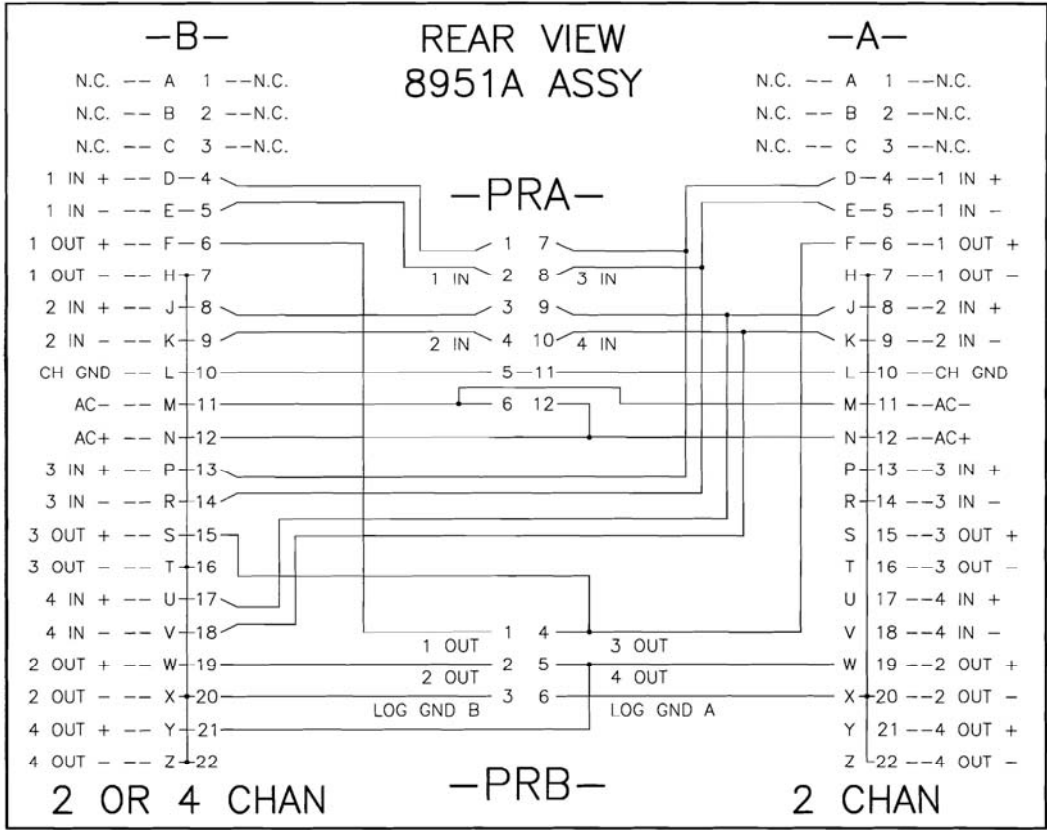

Appendix C

PREEMPT PANEL

P/N 8509#12127

-PRA1-

OPTICOM PREEMPT FIELD
CONNECTION CABLE

P/N 6909

TERM	FUNCTION	COLOR	PIN
PE-3	C DET INPUT	BROWN	1
PE-5	26V COMMON	RED	2
PE-4	D DET INPUT	YELLOW	3
PE-8	26V COMMON	BLUE	4
PE-14	EARTH GROUND	GREEN	5
PE-15	AC NEUTRAL	WHITE	6
PE-1	A DET INPUT	GRAY	7
PE-6	26V COMMON	ORANGE	8
PE-2	B DET INPUT	WH/BLK	9
PE-7	26V COMMON	VIOLET	10
****	UNUSED	---	11
PE-16	AC LINE 115VAC	BLACK	12

-PRB1-

OPTICOM BACKPANEL
INTERFACE CABLE

P/N 6901

TERM	FUNCTION	COLOR	PIN
PE-19	C PRE CALL	BROWN	1
PE-20	D PRE CALL	YELLOW	2
PE-13	LOGIC GND B	BLUE	3
PE-17	A PRE CALL	GRAY	4
PE-18	B PRE CALL	ORANGE	5
PE-13	LOGIC GND A	VIOLET	6

-KPF-

PRE FLASH INTERLOCK RELAY ASSY

P/N 0000A

RELAY P/N 1292

BASE P/N 2294

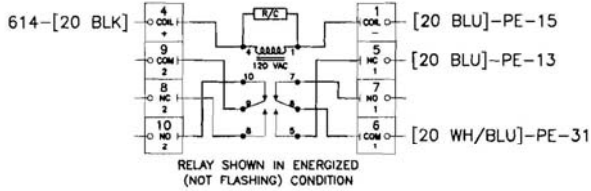

-PE-

P/N 7323

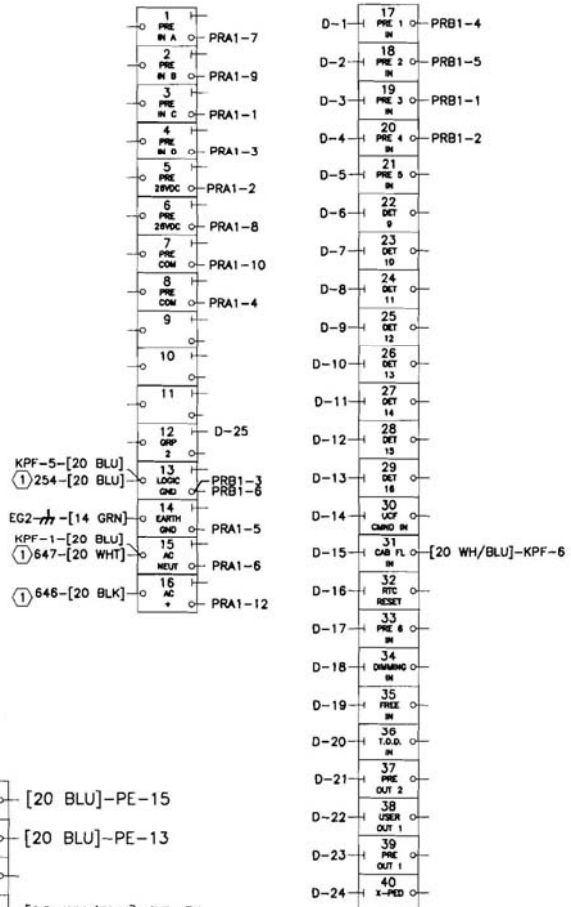

Appendix D

--BIU1--

PIN A	FUNCTION	TERM #	PIN B	FUNCTION	TERM #
1	24VDC IN	A-85	1	+24VDC IN	A-71
2	1 RED	A-87	2	1 YEL	A-88
3	1 GRN	A-89	3	2 RED	A-90
4	2 YEL	A-91	4	2 GRN	A-92
5	3 RED	A-93	5	5 YEL	A-94
6	3 GRN	A-95	6	4 RED	A-96
7	4 YEL	A-97	7	4 GRN	A-98
8	5 RED	A-73	8	5 YEL	A-74
9	5 GRN	A-75	9	6 RED	A-76
10	6 YEL	A-77	10	6 GRN	A-78
11	7 RED	A-79	11	7 YEL	A-80
12	7 GRN	A-81	12	8 RED	A-82
13	8 YEL	A-83	13	8 GRN	A-84
14	TDC OUT 1	A-29	14	TDC OUT 2	A-30
15	PRE STATUS 1	A-31	15	PRE STATUS 2	A-32
16	PRL IN 1	A-33	16	PRL IN 2	A-34
17	TEST A	A-35	17	TEST B	A-1
18	AUTO FLASH	A-2	18	DIM ENABLE	A-3
19	MCE	A-4	19	INT ADV	A-5
20	MIN RCL	A-0	20	EXT START	A-7
21	TBC ON LINE	A-8	21	ST R1	A-15
22	ST R2	A-10	22	MAX II R1	A-17
23	MAX II R2	A-18	23	FO1	A-19
24	FO2	A-20	24	CNA1	A-21
25	WRM	A-22	25	1PC	A-10
26	2 PC	A-11	26	3 PC	A-12
27	4 PC	A-13	27	OPTO COM	A-14
28	ADDR 0	A-38	28	ADDR 1	A-39
29	ADDR 2	A-40	29	ADDR 3	A-41
30	DATA XMIT	A-37	30	DATA RCV	A-36
31	EARTH GND	A-27	31	LINE FREQ	A-28
32	LOGIC GND	A-42	32	LOGIC GND	A-72

--BIU2--

PIN A	FUNCTION	TERM #	PIN B	FUNCTION	TERM #
1	24VDC IN	B-85	1	+24VDC IN	B-71
2	9 RED	B-87	2	9 YEL	B-88
3	9 GRN	B-89	3	10 RED	B-90
4	10 YEL	B-91	4	10 GRN	B-92
5	11 RED	B-93	5	11 YEL	B-94
6	11 GRN	B-95	6	12 RED	B-96
7	12 YEL	B-97	7	12 GRN	B-98
8	13 RED	B-73	8	13 YEL	B-74
9	13 GRN	B-75	9	14 RED	B-76
10	14 YEL	B-77	10	14 GRN	B-78
11	15 RED	B-79	11	15 YEL	B-80
12	15 GRN	D-81	12	16 RED	D-82
13	16 YEL	H-83	13	16 GRN	H-84
14	TDC OUT 3	D-29	14	FREE/COORD	D-30
15	PRE STATUS 3	H-31	15	PRE STATUS 4	H-32
16	PRL STATUS 5	D-33	16	PRL STATUS 6	D-34
17	PRF IN 3	R-35	17	PRF IN 4	R-1
18	PRE IN 5	B-2	18	PRE IN 0	B-3
19	CNA II	B-4	19	SPARE	B-5
20	SPARE	B-0	20	SPARE	B-7
21	SPARE	B-8	21	INH MAX R1	B-15
22	INH MAX R2	B-10	22	LOCAL FLASH	B-17
23	MMU FLASH	B-18	23	ALARM 1	B-19
24	ALARM 2	B-20	24	FREE	B-21
25	TEST C	B-22	25	5 PC	B-10
26	6 PC	B-11	26	7 PC	B-12
27	8 PC	B-13	27	OPTO COM	B-14
28	ADDR 0	B-38	28	ADDR 3	B-41
29	ADDR 2	B-40	29	ADDR 3	B-41
30	DATA XMIT	B-37	30	DATA RCV	B-36
31	EARTH GND	B-27	31	LINE FREQ	B-28
32	LOGIC GND	B-42	32	LOGIC GND	B-72

Pre-empt status outputs

SECTION THREE
SPECIFICATION
CABINET POWER SUPPLY

1.0 INTRODUCTION

The TS 2 cabinet power supply shall provide regulated DC power, unregulated AC power and a line frequency reference for the TS 2-detector rack, Bus Interface Units, load switches, and other auxiliary equipment. As a minimum, the power supply shall meet all applicable requirements of the NEMA TS 2-2003 Standard. Where differences occur, this specification shall govern.

2.0 ENCLOSURE

2.1 The power supply shall be compact so as to fit in limited cabinet space. It shall be capable of being mounted on a shelf. In addition, the power supply shall be capable of being wall mounted using key-hole slots on the rear of the power enclosure.

2.2 The power supply shall be constructed of sheet aluminum and shall be finished with an attractive and durable protective coating.

3.0 PRINTED CIRCUIT ASSEMBLIES

3.1 MATERIALS

All printed circuit boards shall be made from NEMA FR.-4 glass epoxy or equivalent (see NEMA LI-1989 Industrial Laminated Thermosetting Products).

3.2 DESIGN

All printed circuit boards shall meet the following requirements to enhance reliability:

- All plated-through holes and exposed circuit traces shall be plated with solder.
- Both sides of the printed circuit board shall be covered with a solder mask material.
- The circuit reference designation for all components and the polarity of all capacitors and diodes shall be clearly marked adjacent to the component. Pin 1 for all integrated circuit packages shall be designated on both sides of all printed circuit boards.
- All electrical mating surfaces shall be gold plated.
- All printed circuit board assemblies shall be coated on both sides with a clear moisture-proof and fungus-proof sealant.

4.0 ENVIRONMENTAL REQUIREMENTS

The power supply shall perform its specified functions when the ambient temperature and humidity are within the specified limits defined in Section 2 of NEMA TS 2-2003 Standard.

5.0 ELECTRICAL REQUIREMENTS

As a minimum, the electrical requirements shall follow those described in Section 5 of the NEMA TS 2-2003 Standard, plus all other applicable sections.

6.0 INPUT / OUTPUT CONNECTIONS

6.1 PIN CONNECTIONS

The power supply connector shall be located on the front of the unit, have a metallic shell which is connected to the chassis ground internally and mate with an MS3106 (-)18 - 1SW cable connector, or equivalent.

Connector pin terminations shall be as follows:

PIN	FUNCTION
A	AC Neutral
B	Line Frequency Reference
C	AC Line
D	+ 12 VDC
E	+ 24 VDC
F	Reserved
G	Logic Ground
H	Earth Ground
I	12 VAC
J	Reserved

7.0 INDICATORS AND TEST POINTS

7.1 INDICATORS

The power supply shall include LED indicators to display the status of all outputs.

7.2 TEST POINTS

The power supply shall include banana jack style test points for the following signals:

- + 24 VDC
- Logic Ground

8.0 TEST

The functions of each power supply shall be thoroughly tested to insure compliance with the requirements of this specification. Upon completion of initial tests, each power supply shall be burned in at a minimum of 74 degrees C for 48 hours. After burn-in, the functions of the power supply shall be re-tested to insure satisfactory operation.

SECTION FOUR
SPECIFICATION
MALFUNCTION MANAGEMENT UNIT

1. INTRODUCTION

- 1.1. This specification applies to a device conforming to and exceeding the standards set forth by the National Electrical Manufacturer's Association (NEMA) for the traffic signal control industry. The unit defined applies to two standards; the NEMA TS2 standard for a Malfunction Management Unit (MMU), and the NEMA TS 1 standard for a 12 Channel Conflict Monitor.
- 1.2. The unit shall, as a minimum, comply with both these standards for all physical, electrical, environmental, and functional requirements. In cases where the two standards are mutually exclusive; the unit shall conform to the TS2 standard definitions. The definitions provided here are then for features and functionality that exceeds these two standards. This specification may on occasion repeat or re-iterate NEMA definitions and descriptions for clarity.

2. GENERAL DESCRIPTION

- 2.1. The unit shall be an event logging MMU with major status LED's, a keyboard, and a menu driven LCD display format. The unit shall provide RS-232 and RS-485 (TS2 Port 1) ports, in addition to the standard MS-A and MS-B connectors. The unit shall meet all the requirements of TS1-1989, TS2-1992, and TS2-1998 that are applicable to the operation of a Conflict Voltage Monitor Unit and/or Malfunction Management Unit, including a Port 1 HDLC interface. It shall not be acceptable to provide LED's and DIP switches only as the user interface.

3. OPERATING MODES

- 3.1. The unit shall be capable of accepting either the TS1 style or TS2 style jumper cards within the same unit without modification to the unit other than simple insertion and removal of either card.
- 3.2. The unit shall place itself in a fault state if both cards are inserted at the same time. Only one card inserted at a time shall allow normal operation.
- 3.3. The unit shall provide the following modes:
 - 3.3.1. When the TS1 card (only) is inserted, the unit shall default to TS1, 12 Channel Conflict Monitor operation. Port 1 operation is disabled and not required. In this mode, programming of Minimum Flash, Minimum Yellow Inhibit, CVM latch, and 24V latch shall revert to keyboard entry.
 - 3.3.1.1 The unit shall provide for a special mode of TS1 compatible

operation by modification of internal jumpers. In this mode, the I/O shall be configured for compatibility with the PEEK ELRA, ELRB, LSM, and LNM monitors to provide status bits A, B, C, and DC Red Monitor Inhibit.

3.3.2. When the TS2 card (only) is inserted, the unit shall default to TS2, MMU operating mode. This operation consists of two modes as defined by the TS standard. In either mode, programming of Minimum Flash, Minimum Yellow Inhibit, CVM latch, and 24V latch shall revert to jumper programming on the TS2 card.

3.3.2.1. Type 12 mode shall be in effect when type input (A-HH) is not true. This mode shall be downward compatible with TS1 operation other than use of the TS2 card. This mode provides twelve R-Y-G-W channels. Port 1 comm is not required.

3.3.2.2. Type 16 mode shall be in effect when type input (A-HH) is true. This mode provides sixteen R-Y-G channels. Port 1 comm is required unless defeated by applying logic ground to Port 1 pin 10.

4. FRONT PANEL AND USER INTERFACE

4.1. The unit front panel shall provide a set of basic status LED's, reset button, and a keyboard with LCD display.

4.2. LED's. The following LED indications shall be provided with the indicated functions:

- Power indication
- Fault indicator
- Diagnostic indicator
- Type 16 indicator
- Transmit indicator
- Receive indicator
- Local Flash indicator

4.3. Reset Push-button. The reset push-button shall clear any latched failures and cause the output relay to energize. The reset push-button shall also re-configure the unit, e.g. if the type (12) or (16) mode has been changed. The reset button shall be a "one time" reset and shall not continuously reset the unit when depressed. A new activation of the button shall be required to clear each new failure. All faults described as "latched" shall be retained indefinitely until reset, even through power interruption. All faults that are described as "non-latched" may self heal if the fault conditions return to normal and shall not require manual reset.

4.4. Display. The unit shall provide, as a minimum, and extended temperature range, 4x20, "supertwist" LCD display, with backlight. The display shall provide for viewing of current status, operation of menus, unit configuration, viewing of event logs, and viewing of other status information as defined by this specification. Display functions shall be as follows:

4.4.1. Backlight. The backlight shall be activated by any key and shall turn off

after 10 minutes of keyboard inactivity.

4.4.2. Contrast. The contrast adjustment shall be 16 level controlled by a dedicated key on the keypad.

4.4.3. Display Information. The unit shall be, as a minimum, capable of displaying the following:

- The active channel for all 16 channels, indicating the current R, Y, G, W.
- The status of all AC signals and inputs in volts AC.
- Current status of all I/O (red enable, type input, etc.) and relays.
- All programming features – standard and optional.
- Modes of failure – all faults and flash conditions.
- Time of day, date, year.
- Historical log information, including event logs, voltage logs, and blink logs
- Minimum flash time.
- Program card jumper status (TS1 and TS2)
- Port 1 signal status from the controller (when Port 1 used)

4.5. Keypad. The user interface keypad shall provide tactile and audible feedback and shall be labeled to indicate its function.

5. PROGRAMMING

5.1. Menu Driven Format. The MMU/monitor shall contain a menu-driven program for data entry, retrieval and status viewing. Use of dip switches shall not be acceptable.

5.2. Programming functions. The unit shall be capable of programming the following information:

- Setting time and date (this information shall come from the controller when Port 1 is enabled)
- Configuring all functions defined as “optional” or “user configurable”
- Setting TS1 mode minimum flash time, CVM & 24 latch mode, min yellow disables
- Setting up and clearing event logs.

5.3. Security code. A 4 digit security option shall be provided to restrict user program entry when desired. When used, screens and data settings can be viewed (only) without the security code: no data entry is allowed.

6. ENHANCED FEATURES DETAIL

6.1. Hardware Features.

6.1.1. Clock. The unit shall provide an internal Y2K compatible 99-year clock for purposes of time recording events. In TS1 mode or TS2 type 12 mode, the clock shall be set via the keyboard. In TS2 type 16 mode, the clock shall be automatically set via Port 1 from the controller.

6.1.2. RS-232 port. In addition to Port 1, an RS-232 port shall be provided on

the front panel for access to internal data from the unit.

- 6.1.3. Voltage measuring (and displaying). The unit shall provide analog to digital processing on AC line, Red Enable, and all 48 signal inputs to give numeric readouts of each in volts AC. For a sinusoidal waveform, accuracy for full-wave and half-wave signals shall be (3%, or reading, or 2 VRMS, whichever is greater).

6.2. Status Display Features

- 6.2.1. Controller Output Status on Port 1. When in TS2 type 16 port 1 mode, an additional status screen shall be provided to view R-Y-G status per the message frames sent by the controller (in addition to the normal status as determined by field AC inputs).
- 6.2.1. I/O status. The unit shall also be capable of displaying the current status of:
 - All R-Y-G-W status
 - AC Line Voltage
 - Relays, all non-signal inputs, reset button
 - All signal input AC Voltages
 - Jumpers on the compatibility card (TS1 or TS2)
- 6.2.3. Latching of I/O status. The unit shall latch all status at the time of a fault except the relays, non signal inputs, and reset button. These shall be current, regardless of fault.
- 6.2.4. Last N Playback. A special key shall be provided on the keypad which allows the user to view the last twenty G-Y-R (W) displays leading up to either the active display at the moment pressed, during the current fault, or for any historical fault logged in memory. The last “N” displays shall each indicate the screen’s time duration and can be stepped manually through each of the 20 displays.
- 6.2.5. Special “Display G as W”. This function shall allow a ped channel with walk on green to be configured so that when the green is on a “W” is displayed. This function is useful for type 16 mode where walks must be monitored on green (no walk inputs).
- 6.2.6. Event logs, Blink Logs, and Voltage Logs. The unit shall be capable of displaying historical information relative to these functions as described in the Logging Features section (see 6.4)
- 6.2.7. Logged status. When a fault is recorded in the event log and the fault pertains to signal inputs, the status at the time of fault of all R-Y-G-W inputs, controller Port 1 indications, AC line voltage, relays, non-signal inputs, the reset button, and the 20 “Last N” screens leading up to the fault shall also be stored along with the event log fault for user viewing. Recorded faults that provide this information shall, as a minimum, include; Conflict, Red Failure, any Clearance Failure, and Multiple Indications Failure.

6.3. Monitoring Modes. The unit shall provide the following monitoring modes.

6.3.1. NEMA modes. The following modes are defined by the NEMA standard and are re-stated here for clarity:

- Conflict (latched)
- Red Failure (latched)
- Yellow Plus Red Interval (latched, green to conflicting green must be greater than 2.7 seconds)
- Minimum Yellow Change interval (latched, yellow must be greater than 2.7 seconds)
- Voltage monitoring (non latched if not programmed to do so, +24I, +24VII, CVM, Fault Monitor)

6.3.2. Multiple (Dual) Indications. This fault shall be optional and configurable per channel and shall disallow G-Y-W on with Red or G-W on with Yellow when each channel is enabled. This failure shall always be considered a latched failure when enable.

6.3.3. Field Check Fault. Type 16 mode only. This fault shall be optional and configurable per channel and shall compare controller Port 1 message with field signals (see 6.7.2.4). A fault shall occur if these are different. This failure shall always be considered a latched failure when enabled.

6.3.4. No Yellow. This feature shall require that a yellow change indication follows any “established” green. An established green shall be considered any green on for greater than the conflict recognition time (350 milliseconds) or more. A fault shall be declared if a yellow signal does not appear within 2.5 seconds of the end of such green. The feature shall be disabled by minimum yellow change disable programming via keyboard entry (TS1) or jumper on the compatibility card (TS2). This failure shall always be considered a latched failure when enabled.

6.3.5. Watchdog Fail. This failure shall be optional via keyboard programming. When enabled, the unit shall monitor a special input that receives the Flashing Logic output signal from the controller. If enabled but the watchdog input has failed to receive a periodic change of state (DC square waveform of 0 to +24 VDC), a “Watch Dog” Fault shall be declared. This failure shall always be considered a latched failure when enabled.

6.3.6. Type Fail. The unit shall declare a fault upon power-up if the Type Input (type 12 vs. type 16 mode) has changed states since the last power-down. A manual reset shall be required to recognize the new state and resume normal operation. As long as power remains on after the input changes, the input shall not be recognized and the existing state shall remain in effect. No fault shall be declared until power cycles down then up. This failure shall always be considered a latched failure.

6.3.7. Card Fail. The unit shall declare a fault if the compatibility program card is not inserted, or can't be read, or is a TS1 type card with TS2 type 16 mode selected, or the card has been changed from one version to another. In the case of a changed card, application of reset shall cause the unit to accept the new card. This failure shall always be considered a latched

failure.

6.3.8. Diagnostic Fail. Two types of diagnostic fault modes shall be provided as follows:

6.3.8.1. Software. The Unit has failed program based diagnostics (RAM, ROM, EEPROM, etc.)

6.3.8.2. Hardware. The CPU is not toggling watchdog circuit.

6.4. Event logs. The unit shall provide event logging of significant occurrences. Each log shall be identified and time stamped. Event logs shall be viewable via the keyboard and display.

6.4.1. The event logs shall provide as a minimum:

- Date and time of each event
- Power on/off occurrences
- All Faults and type of fault
- Last time the message log was cleared
- Manual pushbutton monitor resets
- That a keyboard change to the configuration has occurred
- Voltage logs over and above a user-defined threshold
- Blink logs
- Additional information screens at time of fault for field signal related faults, voltage logs, and blink logs (see 6.4.2)

6.4.2. Additional information log screen. An “additional information screen” shall be provided for certain types of events.

6.4.2.1 Field signal faults. Field signal faults shall include, as a minimum, Conflict, Red Failure, any Clearance Failure, and Multiple Indications. For these faults, the following additional information screens shall be provided. Each shall indicate the status at the time of fault:

- G-Y-R-W AC Input Indications
- G-Y-R-W status per controller via port 1 Comm (if port 1 enabled)
- AC line voltage
- Status of relays, all non-signal inputs, and the reset button
- G-Y-R-W AC Input Voltages
- The 20 last “N” screens leading up to the fault at the time of fault

6.4.2.2. Voltage logs. For Voltage log events the unit shall provide additional screens that include a voltage log period screen (duration of log) plus a dip and peak histogram screen. (see 6.5).

6.4.2.3. Blink logs. For Blink Log events the unit shall provide additional screens that include a “Blink On” and “Blink Off” log screen (see 6.6).

6.4.3. Event capacity. The unit shall provide a minimum of 100 events.

6.5. Voltage Log Description. The unit shall allow the user to optionally set specific

thresholds over or under which the unit will record. The unit shall begin a “voltage log session” when the AC line voltage falls outside this range. The session shall continue until the AC line voltage has returned to within threshold values for 5 consecutive minutes. At that point the log shall end and be recorded as a “voltage log” within the event log. The record shall include as a minimum:

- The time and date of occurrence
- Start and end time of the logging session
- The number of times the AC line made excursions below threshold during the session
- The number of times the AC line made excursions above threshold during the session
- The lowest value of the AC line during the session
- The highest value of the AC line during the session
- A “Dip Histogram” which bins the number of below threshold excursions into a minimum of 5 ranges.
- A “Peak Histogram” which bins the number of above threshold excursions into a minimum of 2 ranges.

6.6. Blink Log Description. The unit shall provide a “Blink Log” record when a field signal “Blinks On” or “Blinks Off”. A blink shall be considered any signal that is either on or off for less than 150 ms. The unit shall begin a “blink log session” when any enabled signal first blinks on or off. The session shall continue until no enabled signals have blinked for 5 consecutive minutes. At that point the log shall end and be recorded as a “blink log” within the event log. The record shall include as a minimum:

- The time and date of occurrence
- Start and end time of the logging session
- The number of times each signal blinked ON during the session
- The number of times each signal blinked OFF during the session

6.7. Configurable options. The following options shall be configurable via the keyboard.

6.7.1. Per unit options (applies to unit or all channels):

6.7.1.1. Set Field Check Enable unit wide (see 6.7.2.4, must also set per channel if used)

6.7.1.2. Set Red Fail = G-Y-R Only. When enabled, Red Fail (absence of signal) can be detected even with the walk signal active. It shall apply to TS1 and TS2 type 12 modes only (see 6.7.2.6).

6.7.1.3. Set Fault Re-Initialize. When enabled the unit shall re-initialize the controller after the MMU exits flash. The unit shall be configurable for the following options:

- No re-initialize
- Re-initialize controller after any reset or self healing fault (CVM, +24 when no latched)
- Re-initialize controller after self healing fault but not reset

- 6.7.1.4. Set Watchdog Enable. When enabled, the watchdog feature shall be in effect (see 6.3.5).
- 6.7.1.5. 24V and CVM latch. This programming shall apply to TS1 mode only to provide programming of the minimum flash time via the keyboard. This programming shall be derived from jumpers on the TS2 program card when that card is inserted. When enabled, these faults shall become latched and shall require manual reset to exit the fault state. When not enabled the unit shall be able to self-heal and exit the fault state automatically.
- 6.7.1.6. Min Flash. This programming shall apply to TS1 mode only to provide programming of the minimum flash time via the keyboard. This programming shall be derived from jumpers on the TS2 program card when that card is inserted.
- 6.7.1.7. Fast Flash Monitoring. When enabled the unit shall allow recognition of Canadian Fast Flash advance left signals between 120 and 180 FPM, 50% duty cycle (+/- 10%).
- 6.7.1.8. Status Bit Configuration. Allows programming of the status bit mode when the unit is configured with special jumpers (see 3.3.1.1). The unit shall provide the following options:
 - LSM/LNM/ELRB compatible
 - ELRA compatible

6.7.2. Per Channel Options (function applies only to channels enabled)

- 6.7.2.1. G-W-Y vs. R. When enabled, green, walk, or yellow cannot be on red (see 6.3.2). The unit shall provide the following configurable options for each channel:
 - Feature = OFF that channel
 - Feature = ON that channel
 - Feature = "Auto" that channel, the red must cycle off once after power up to enable
- 6.7.2.2. G-W vs. Y. When enabled, green or walk cannot be on with yellow (see 6.3.2). The unit shall provide the following configurable options for channels in this monitor mode:
 - Feature = OFF that channel
 - Feature = ON that channel
- 6.7.2.3. Display Green as Walk. When enabled, "W" will be displayed instead of "G" when the green input of that channel is active (used for Ped channels).
- 6.7.2.4. Field Check Fault. When enabled, specific colors from the AC field inputs must match the controller Port 1 frames for that channel (see 6.3.3). The unit shall provide the following

configurable options for this monitor mode:

- Don't compare, channel not used or option not required
 - Green (walk) only must match
 - Green (walk) and yellow must match
 - Green (walk), yellow and red must match that channel
- 6.7.2.5. Min Yellow Disable. See 6.3.1, 6.3.4. This programming shall apply to TS1 mode only to provide programming of Min Yellow Disable via the keyboard. This programming shall be derived from jumpers on the TS2 program card when that card is inserted. This programming shall disable minimum yellow and no yellow monitoring but shall not disable Yellow Plus Red Interval (Clearance Failure) monitoring (see 6.7.2.7).
- 6.7.2.6. Set Red Fail = G-Y-R only per channel. When enabled, Red Fail (absence of signal) can be detected even with the Walk signal active. It shall apply to TS1 and TS2 type 12 modes only. Note that the unit shall also provide this programming on a per unit basis (see 6.7.1.2) such that both the per unit and individual channel options must be on for a given channel to provide this function.
- 6.7.2.7. Yellow Plus Red Interval Monitor Inhibit (Green to Green Monitor inhibit) See 6.4.7. This programming shall apply to all modes (TS1 or TS2). When ON, the channel shall not require a minimum of 3.7 seconds from end of green of that channel to another conflicting green.
- 6.7.2.8. Blink Log Enable. When enable, blink logs will be recorded on that channel if blinks occur. If not enabled, no blink logs shall occur resultant from that channel. This feature shall be provided to be able to turn off blink logging on nuisance channels.
- 6.7.3. Set Time and Date. The unit shall provide for setting time and date via the keyboard and display. Manually setting of the time and date shall not be necessary in TS2 type 16 mode when Port 1 is operational. In this mode the time and data shall be automatically loaded from the controller.
- 6.7.4. Set up Voltage logs. The unit shall provide for user configuration of above and below threshold values that determine voltage log recordings (see 6.5)
- 6.7.5. Security code. The unit shall provide an optional, 4 digit, user configurable security code. When a security code is in effect, the unit shall revert to a "Read Only" device for users without knowledge of the security code. Entry of the code shall be first required to re-configure programmable parameters.
- 6.7.6. Clear Event Log. This unit shall provide a means to clear all event logs within the unit. This action shall itself be recorded in the event log, and shall be the only event in the log immediately after clear.

6.7.7. Set configuration to defaults. The unit shall provide a means of quickly and easily setting the unit configuration to pre-set values. As a minimum, the following configurations shall be provided;

- A basic configuration without enhanced features enabled (factory ship)
- A configuration suitable for basic feature testing by an auto-test unit
- A configuration suitable for enhanced feature testing by an auto-test unit

6.8 Diagnostics. The unit shall provide internal diagnostic algorithms to check status of I/O and various components. The diagnostics routine shall be a sub-menu of the standard operating firmware and shall not require insertion of a special PROM. The unit shall not operate as a normal monitor in the diagnostics mode, nor shall it allow continuous activation of the output relay. It shall be acceptable to require special loop back or interface cables, and/or a dedicated test box to operate the diagnostics algorithms. Certain of the tests may be automatic, others may require prompted user action.